

Republic of the Philippines
Department of Trade and Industry
CENTER FOR INTERNATIONAL TRADE EXPOSITIONS AND MISSIONS
Golden Shell Pavilion, Roxas Blvd. Cor. Gil Puyat Ave., Pasay City

Solicitation No.: CITEM-2024-0175

REQUEST FOR QUOTATION
(NEGOTIATED PROCUREMENT – SMALL VALUE PROCUREMENT)

The Center for International Trade Expositions and Missions (CITEM) invites all interested parties to submit quotation for:

**SUPPLY, MOBILIZATION, INSTALLATION, DISMANTLING OF VENUE
ENHANCEMENTS AND DISPLAY REQUIREMENTS**

(Please see attached Request for Quotation Form and Sample images for more details and reference.)

Approved Budget for the Contract	: PHP300,500.00
Deadline of Submission of Eligibility Documents and Financial Bid	: 16 September 2024, 05:00PM
Schedule of Opening of Bids	: 17 September 2024, 02:00PM

Conduct of Opening of Bids shall be held virtually thru Microsoft Teams or Zoom and shall be open to all prospective bidders. Link of the Opening of Bids may be requested through the BAC Secretariat at citembac@citem.com.ph. The link will be released on the actual day of the procurement activity.

The *Notice of Award* shall only be issued to the lowest calculated and responsive bidder who has complied with the following documentary requirements below, submitted in an enclosed, sealed and properly labeled envelope or compressed folder:

Eligibility Documents (1st Envelope / Compressed Folder)

- Mayor's Permit for the current year or for individuals exercising a profession, BIR Certificate of Registration**
Expired Mayor's permit with Official Receipt of renewal application shall be accepted provided that the renewed permit shall be submitted before the award of the contract.
- Valid PhilGEPS Registration Number (evidenced by a certificate or screen shot)**
PhilGEPS Certificate of Platinum Membership may be submitted in lieu of Mayor's Permit and PhilGEPS Registration Number.
- Notarized Omnibus Sworn Statement**
- Notarized Special Power of Attorney, Notarized Secretary's Certificate or Board/Partnership Resolution for partnership, corporation, cooperative, or joint venture, whichever is applicable**

Financial Bid (2nd Envelope / Compressed Folder)

- Quotation using the attached Request for Quotation (RFQ) Form duly signed by the authorized representative.**

To encourage the sanctity of the bids, bidders must submit these documents separately, on the above stated date and time, either on the following:

- Physical Submission at the CITEM Office, Golden Shell Pavilion, Roxas Blvd. cor. Gil Puyat Ave., Pasay City, or
- Online submission to the BAC Secretariat through email at citembac@citem.com.ph. A password protection may be inflicted in the compressed folders to ensure security of the documents. The password must be disclosed on or before the date and time of the Opening of Eligibility Documents and Financial Bid as indicated above. Failure to disclose the password during the opening of bids may result to non-responsiveness of the bid.

CITEM-BAC reserves the right to reject any or all bids disadvantageous to, waive any formality or accept such bids as may be considered advantageous to the government. Further, CITEM-BAC assumes no obligation whatsoever to compensate or indemnify the bidders for expenses or losses that may be incurred in participating in this bidding.

For inquiries, please contact the CITEM Bids and Awards Committee Secretariat, at telephone no. (02) 8-831-2201 local 309/294 or email at citembac@citem.com.ph.

ATTY. ANNA GRACE I. MARPURI
Chairman, Bids and Awards Committee



REQUEST FOR QUOTATION

- Shopping with ABC of Php 50,001 and above Small Value Procurement with ABC of Php 50,001 and above
 Lease of Real Property and Venue Others:

Date: 12 September 2024

Company Name: _____

RFQ No.: 2024-0175

Address: _____

Contact No.: _____

Gentlemen:

Please quote hereunder your lowest possible price(s) for the following article(s)/work(s) which are urgently needed by this office. It is requested that the quotation be sealed, signed, and stamped in an envelope or compressed folder and submitted to CITEM BAC / citembac@cittem.com.ph.

Deadline of Submission of Eligibility Documents and Financial Bid: 16 September 2024	Time: 05:00PM
Schedule of Opening of Bids: 17 September 2024	Time: 02:00PM Venue: Zoom

SUPPLY, MOBILIZATION, INSTALLATION, DISMANTLING OF VENUE ENHANCEMENTS AND DISPLAY REQUIREMENTS

(Please see attached sample image of Pedestals & Long tables, Mannequin and Plants for reference)

TOTAL APPROVED BUDGET FOR THE CONTRACT: PHP300,500.00

QTY	UNIT	ARTICLE / WORK / DESCRIPTION / SPECIFICATION	UNIT PRICE	AMOUNT
5	units	I. SUPPLY OF PEDESTALS AND LONG TABLE (PURCHASE) a. 0.30m x 0.30m x 0.60m H Wooden Pedestals in approved finish ABC: PHP1,200.00 per unit or total of PHP6,000.00		
5	units	b. 0.30m x 0.30m x 0.80m H Wooden Pedestals in approved finish ABC: PHP1,500.00 per unit or a total of PHP7,500.00		
5	Units	c. 0.30m x 0.30m x 1.00m H Wooden Pedestals in approved finish ABC: PHP1,800.00 per unit or a total of PHP9,000.00		
2	units	d. 0.80m x 0.30m x 0.50m H Wooden Pedestals in approved finish ABC: PHP2,300.00 per unit or a total of PHP4,600.00		
1	unit	e. 1.20m x 0.45m x 0.75m H Long table with Wooden top in laminate finish with 1"x1" square tubular metal in black paint finish ABC: PHP9,500.00 <i>(Finals color/swatch of laminate of all pedestals to be advised)</i>		
10	units	II. SUPPLY OF MANNEQUIN (PURCHASE) a. Supply of dress form mannequin ABC: PHP4,500.00 per unit or a total of PHP45,000.00		
8	units	III. SUPPLY OF PLANTS (PURCHASE) a. Traveler's Palm (with approved pot) ABC: PHP9,500.00 per unit or a total of PHP76,000.00		
6	units	a. Elephant Ears (with approved pot) ABC: PHP9,500.00 per unit or a total of PHP57,000.00		



6	units	a. <i>Monstera (with approved pot)</i> ABC: PHP7,500.00 per unit or a total of PHP45,000.00		
10	units	a. <i>Birds of Paradise (with approved pot)</i> ABC: PHP4,500.00 per unit or a total of PHP45,000.00		
20	units	a. <i>Mayana Plant (with approved pot)</i> ABC: PHP500.00 per unit or a total of PHP10,000.00		
TOTAL BID OFFER				

Scope of Work:

1. The contractor shall Install, Dismantle, and Haul the items listed above on the specified materials and specifications.
2. The contractor shall provide proofs and swatches prior to final fabrication for approval unless waived by an EDD representative but to guarantee the best output.
3. The contractor shall ensure the durability and quality of the items.
4. The contractor shall deliver the items properly and in good condition (without smudge, dirt, stains and the like) starting on ingress of **16 October 2024** and egress on **19 October 2024, 07:00PM – 12:00MN**.
5. The contractor shall complete the delivery of the requirements on **16 October 2024, 10:00PM**. A 10% deduction shall be applied for incomplete delivery of the requirements deemed unreasonable.

Note:

All above item/s is/are the property of CITEM after the event unless indicated as rental or otherwise. Items shall be delivered to the CITEM office and shall be received by the General Services Division (GSD).

Terms and Conditions:

- 1) Delivery period: _____ working days upon acceptance of Purchase/Job Order.
- 2) Bid price must be **Inclusive of Value Added Tax**.
- 3) Payment will be processed after receipt of invoice. Other terms of payment will be based on the Contract agreed by the Purchaser and Supplier.
- 4) Any alterations, erasures or overwriting shall be valid only if they are signed or initialed by the bidder or his/her authorized representative.
- 5) Required documents, if any, must be submitted within 3 Days after receipt of notice.
- 6) This requirement is **One Project** having several items that shall be **awarded as One Contract**.

The CITEM-BAC reserves the right to reject any or all bids offer and waive any defects therein and accept bid/s it may consider advantageous to the government.

ATTY. ANNA GRACE I. MARPURI
BAC Chairman

TO: CITEM Bids and Awards Committee:

Per your request, I/we have indicated the prices of the above-mentioned article(s)/work(s) on the unit price/amount column above. I/We also certify that we have read, understood, and shall conform with the terms and conditions of this requirement.

Date Submitted

Signature over printed name of the Authorized Company Representative

Designation: _____

Telephone No(s): _____

Email: _____

PEDESTALS

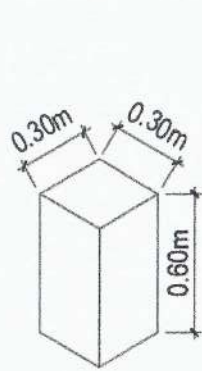

PEDESTAL A
8 UNITS

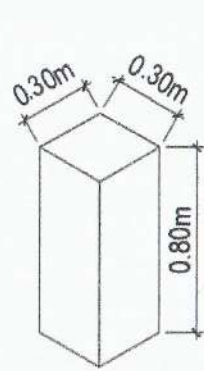

PEDESTAL B
6 UNITS

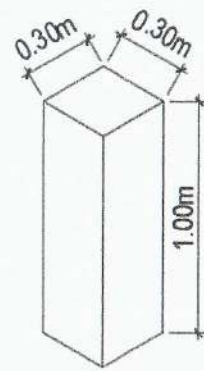

PEDESTAL C
6 UNITS

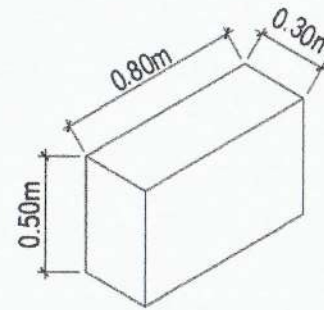

PEDESTAL C
2 UNITS

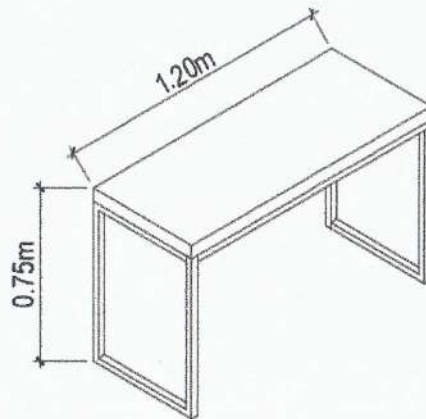

LONG TABLE
1 UNIT

MANNÈQUIN
10 units



PLANTS



TRAVELER'S PALM
8 UNITS



ELEPHANT EARS
6 UNITS



MONSTERA
6 UNITS

PLANTS



BIRDS OF PARADISE
10 UNITS



MAYANA
20 UNITS