

JOB ORDER

CITEM.STR.FR.006

CENTER FOR INTERNATIONAL TRADE EXPOSITIONS AND MISSIONS Golden Shell Pavilion, Roxas Boulevard corner Sen. Gil J. Puyat Avenue 1300 Pasay City, Metro Manila, Philippines ☎ (632) 831-2201 to 09 ext. 218 📠 (632) 831-1388, 832-3965 ✉ info@citem.com.ph 🌐 www.citem.com.ph	dti <small>DEPARTMENT OF TRADE INTEGRATION</small>	JO Number: 2024-0339	JO Date: 08/08/2024	PAGE 1
	PR No.: 2024-0339	PR Date: 08/02/2024		

CONTRACTOR/SUPPLIER <u>EXPO INTERNATIONAL LTD.</u> ADDRESS <u>9F Sankei Bldg., 1-3-1 Kanda-Izumicho Chiyoda-ku, Tokyo, Japan</u> MODE OF PROCUREMENT <u>Overseas Procurement</u>	DELIVERY TERM PAYMENT TERM PLACE OF DELIVERY DATE OF DELIVERY
---	--

Please provide/furnish this office the requirements listed below subject to the terms and conditions contained herein. Address all correspondence to the Center for International Trade Expositions and Missions (CITEM).

DESCRIPTION	QTY/UNIT	UNIT PRICE	AMOUNT
Booth construction for the Philippine Pavilion in Tokyo International Gift Show 2024 Event Date: 04-06 September 2024 Ingress Date: 02-03 September 2024 Booth Size: 90 sqm Location: Tokyo International Exhibition Center, Tokyo, Japan Please see attached for details.	1 lot		JPY 4,860,000.00 (inclusive of tax) or PHP 1,950,804.00
TOTAL AMOUNT IN WORDS: FOUR MILLION EIGHT HUNDRED SIXTY THOUSAND JAPAN YEN OR A TOTAL OF ONE MILLION NINE HUNDRED FIFTY THOUSAND EIGHT HUNDRED FOUR PESOS			JPY 4,860,000.00 OR A TOTAL OF PHP 1,950,804.00

the pavilion will be ready for exhibitor move-in on september 3rd, 12:00. Small details might be necessary to be done after this DATE and time.

This order is placed subject to the following terms and conditions:

The delivery must be made only during office hours to CITEM or as may be specified. Delivery is subject to the acceptance of CITEM's duly authorized representative/official and inspection by CITEM-Management Inspection Team and/or the Commission on Audit. Rejected deliveries are to be withdrawn and/or replaced immediately. Delay in the delivery is subject to the **PENALTY** of 1/10 of 1% of the **TOTAL VALUE** of this ORDER for **EACH DAY OF DELAY**. In case the contractor/supplier does not deliver within the due date, s/he shall be considered in default and will be liable to pay **LIQUIDATED DAMAGES** in the amount of _____ of the **TOTAL AMOUNT** unless the contractor/supplier requested and CITEM granted an extension. The contractor/supplier authorizes CITEM to deduct the amount of undelivered portion and to deduct the penalty and liquidated damages from any of its receivables from CITEM. The contractor/supplier must present a Delivery Receipt and Invoice or Official Receipt with the Purchase Order upon delivery.

Very truly yours, ATTY. ANNA GRACE I. MARPURI Acting DM - Corporate Services Department CONFORME: EXPO INTERNATIONAL LTD. 9F1, SanKei Bldg., 1-3-1 Kanda-Izumicho Chiyoda-Ku, Tokyo Japan (101-0024) Phone (03) 5687-3983, FAX (03) 5687-5437	BUR No. <u>7165-24080858</u> DATE <u>Aug 09, 2024</u> AMOUNT <u>JPY 4,860,000.00 OR PHP 1,950,804.00</u> Funds Available: MALERNA C. BUYAO Chief Controllership	Recommended by: MARJO F. EVIO Acting DM - Service Business Department Approved by: LEAH PULIDO OCAMPO Executive Director
--	---	---



SIDE VIEW



FRONT VIEW







LEFT PERSPECTIVE VIEW



RIGHT PERSPECTIVE VIEW

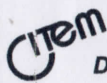

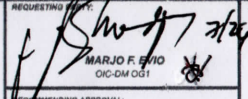
INTERIOR PERSPECTIVE VIEW

 <p>EXPERIENCE DESIGN DIVISION</p>	<p>PROJECT: TOKYO INTERNATIONAL GIFT SHOW</p>	<p>SHEET CONTENT:</p> <p>REVISED DESIGN</p>	<p>DESIGNED BY:</p> <p> MARJIO F. SANTOS JR. SIDS</p>	<p>REQUESTING APPROVAL:</p> <p> MARJIO F. SANTOS JR. OIC-DM OGI</p>	<p>APPROVED BY:</p> <p> LEAH PULIDO OCAMPO Executive Director</p>
	<p>TITLE: PHILIPPINE PAVILION</p>				
<p>DATE / TIME: JULY 26, 2024</p>					

FLOOR PLAN

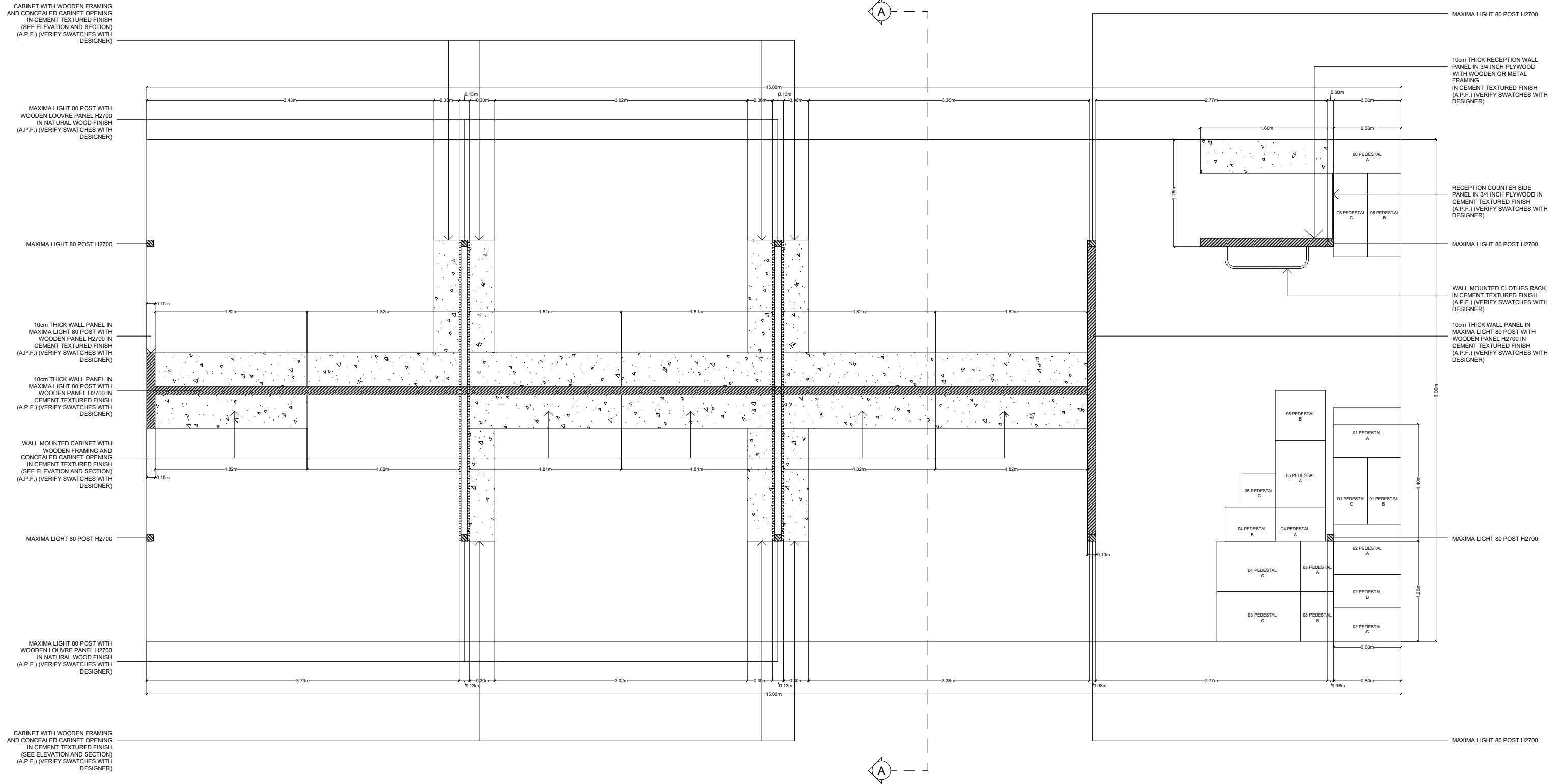

Item	PROJECT:	TIGS 2024
	TITLE:	PHILIPPINE PAVILION
DESIGNED BY:	LOCATION:	TOKYO INTERNATIONAL EXHIBITION CENTER TOKYO, JAPAN
MSJ		
DATE/TIME:	SHEET CONTENT:	SHEET NO.:
08.02.24	FLOOR PLAN	01

SIGNAGE PLAN FRONT VIEW

OVERHEAD SIGNAGE IN MAXIMA
LIGHT 80 POST WITH WOODEN
LOUVRE PANEL H900 IN NATURAL
WOOD FINISH
(A.P.F.) (VERIFY SWATCHES WITH
DESIGNER)

DTI | CITEM LOGO
CUT-OUT GRAPHICS
0.55m X 0.1m X 0.2mH

DESIGN PHILIPPINES LOGO
CUT-OUT GRAPHICS
3.1m X 0.1m X 0.5mH

MANILA FAME LOGO
CUT-OUT GRAPHICS
0.94m X 0.1m X 0.5mH



COMPANY NAME IN DIGITAL PRINT
STICKER CUT-OUT

	PROJECT: TIGS 2024	SHEET NO. 28
	TITLE: PHILIPPINE PAVILION	
	DESIGNED BY: MSJ	LOCATION: TOKYO INTERNATIONAL EXHIBITION CENTER TOKYO, JAPAN
DATE/TIME: 08.02.24	SHEET CONTENT: SIGNAGE PLAN	

SIGNAGE PLAN LEFT SIDE VIEW

DTI | CITEM LOGO
CUT-OUT GRAPHICS
0.55m X 0.1m X 0.2mH

DESIGN PHILIPPINES LOGO
CUT-OUT GRAPHICS
3.1m X 0.1m X 0.5mH

OVERHEAD SIGNAGE IN MAXIMA LIGHT 80 POST
WITH WOODEN LOUVRE PANEL H900
IN NATURAL WOOD FINISH
(A.P.F.) (VERIFY SWATCHES WITH DESIGNER)

MANILA FAME LOGO
CUT-OUT GRAPHICS
0.94m X 0.1m X 0.5mH

COMPANY NAME IN DIGITAL PRINT
STICKER CUT-OUT



	PROJECT:	TIGS 2024
	TITLE:	PHILIPPINE PAVILION
	DESIGNED BY:	MSJ
DATE/TIME:	08.02.24	LOCATION: TOKYO INTERNATIONAL EXHIBITION CENTER TOKYO, JAPAN
	SHEET CONTENT:	SIGNAGE PLAN
		SHEET NO: 29

SIGNAGE PLAN RIGHT SIDE VIEW

DTI | CITEM LOGO
CUT-OUT GRAPHICS
0.55m X 0.1m X 0.2mH

DESIGN PHILIPPINES LOGO
CUT-OUT GRAPHICS
3.1m X 0.1m X 0.5mH

OVERHEAD SIGNAGE IN MAXIMA LIGHT 80 POST
WITH WOODEN LOUVRE PANEL H900
IN NATURAL WOOD FINISH
(A.P.F.) (VERIFY SWATCHES WITH DESIGNER)

MANILA FAME LOGO
CUT-OUT GRAPHICS
0.94m X 0.1m X 0.5mH

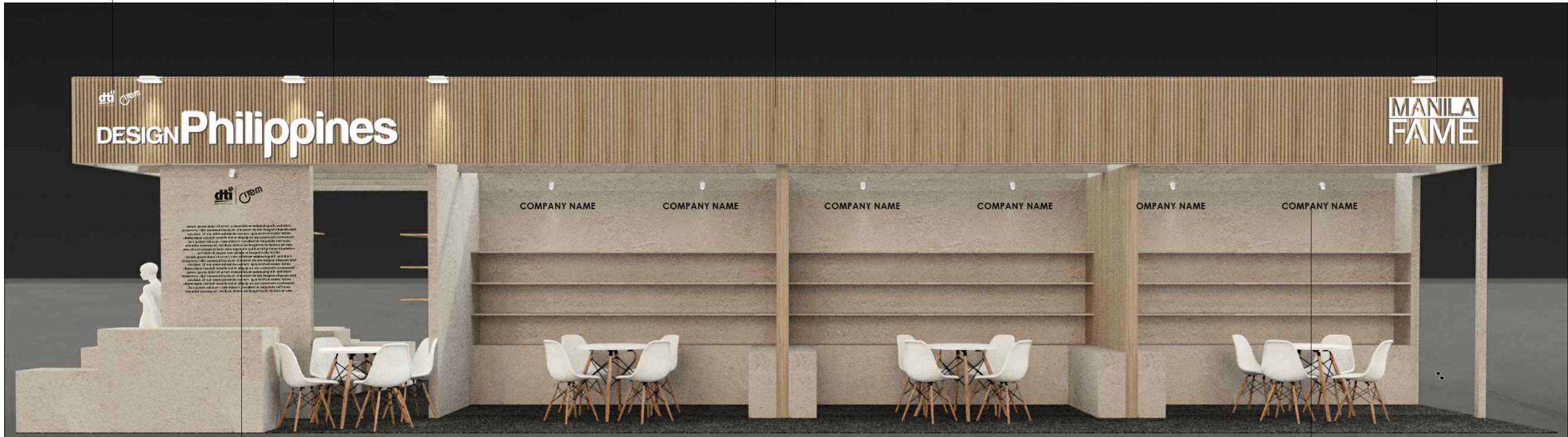

1.5m X 2.7mH DIGITAL PRINT STICKER
CUT-OUT MOUNTED ON WALL PANEL

COMPANY NAME IN DIGITAL PRINT
STICKER CUT-OUT

NOTE

**GRAPHICS IN THIS LAYOUT NOT YET FINAL
DESIGNER TO SUBMIT FINAL ARTWORKS**

	PROJECT:	TIGS 2024
	TITLE:	PHILIPPINE PAVILION
DESIGNED BY:	MSJ	LOCATION: TOKYO INTERNATIONAL EXHIBITION CENTER TOKYO, JAPAN
DATE/TIME:	08.02.24	SHEET CONTENT: SIGNAGE PLAN
		SHEET NO: 30

SIGNAGE PLAN

RIGHT SIDE PERSPECTIVE VIEW

OVERHEAD SIGNAGE IN MAXIMA LIGHT 80 POST WITH WOODEN LOUVRE PANEL H900 IN NATURAL WOOD FINISH (A.P.F.) (VERIFY SWATCHES WITH DESIGNER)

MANILA FAME LOGO CUT-OUT GRAPHICS 0.94m X 0.1m X 0.5mH

DTI | CITEM LOGO CUT-OUT GRAPHICS 0.55m X 0.1m X 0.2mH

DESIGN PHILIPPINES LOGO CUT-OUT GRAPHICS 3.1m X 0.1m X 0.5mH

DTI | CITEM LOGO CUT-OUT GRAPHICS 0.55m X 0.1m X 0.2mH

DESIGN PHILIPPINES LOGO CUT-OUT GRAPHICS 3.1m X 0.1m X 0.5mH

COMPANY NAME IN DIGITAL PRINT STICKER CUT-OUT

1.5m X 2.7mH DIGITAL PRINT STICKER CUT-OUT MOUNTED ON WALL PANEL

MANILA FAME LOGO CUT-OUT GRAPHICS 0.94m X 0.1m X 0.5mH

*****NOTE*****
GRAPHICS IN THIS LAYOUT NOT YET FINAL
DESIGNER TO SUBMIT FINAL ARTWORKS



	PROJECT:	TIGS 2024
	TITLE:	PHILIPPINE PAVILION
DESIGNED BY:	MSJ	LOCATION: TOKYO INTERNATIONAL EXHIBITION CENTER TOKYO, JAPAN
DATE/TIME:	08.02.24	SHEET CONTENT: SIGNAGE PLAN
		SHEET NO: 31

SIGNAGE PLAN

REAR PERSPECTIVE VIEW

OVERHEAD SIGNAGE IN MAXIMA LIGHT 80 POST WITH WOODEN LOUVRE PANEL H900 IN NATURAL WOOD FINISH (A.P.F.) (VERIFY SWATCHES WITH DESIGNER)

MANILA FAME LOGO CUT-OUT GRAPHICS
0.94m X 0.1m X 0.5mH

DTI | CITEM LOGO CUT-OUT GRAPHICS
0.55m X 0.1m X 0.2mH

DESIGN PHILIPPINES LOGO CUT-OUT GRAPHICS
3.1m X 0.1m X 0.5mH

DTI | CITEM LOGO CUT-OUT GRAPHICS
0.55m X 0.1m X 0.2mH

DESIGN PHILIPPINES LOGO CUT-OUT GRAPHICS
3.1m X 0.1m X 0.5mH

COMPANY NAME IN DIGITAL PRINT STICKER CUT-OUT

0.9m X 2.7mH DIGITAL PRINT STICKER CUT-OUT MOUNTED ON WALL PANEL

MANILA FAME LOGO CUT-OUT GRAPHICS
0.94m X 0.1m X 0.5mH

*****NOTE*****
GRAPHICS IN THIS LAYOUT
NOT YET FINAL
DESIGNER TO SUBMIT FINAL
ARTWORKS



	PROJECT:	TIGS 2024
	TITLE:	PHILIPPINE PAVILION
DESIGNED BY:	LOCATION:	TOKYO INTERNATIONAL EXHIBITION CENTER TOKYO, JAPAN
MSJ	DATE/TIME:	08.02.24
SHEET CONTENT:	SIGNAGE PLAN	SHEET NO: 32

TIGS PHILIPPINE PAVILION 2024 CHECKLIST - AUGUST 02, 2024

ITEM NO.	PARTICULARS	DESCRIPTION	QTY	UNIT
1	STRUCTURE	OVERALL STRUCTURE INCLUDING POST, WALLS, LOUVER, BEAMS with appropriate finish (see all details)	1	lot
2	FLOORING	6m x 15m dark grey flooring (see rendering)	1	lot
3	WALL MOUNTED CABINET	WALL MOUNTED CABINET WITH WOODEN FRAMING AND CONCEALED CABINET OPENING IN CEMENT TEXTURED FINISH (SEE ELEVATION AND SECTION) (A.P.F.) (VERIFY SWATCHES WITH DESIGNER)	1	lot
4	CABINET WITH WOODEN FRAMING	CABINET WITH WOODEN FRAMING AND CONCEALED CABINET OPENING IN CEMENT TEXTURED FINISH (SEE ELEVATION AND SECTION) (A.P.F.) (VERIFY SWATCHES WITH DESIGNER)	1	lot
5	01 PEDESTAL A	1m X 0.4m X 1.1mH pedestal with concealed cabinet (see details)	1	set
6	01 PEDESTAL B	1m X 0.4m X 0.9mH pedestal with concealed cabinet (see details)	1	set
7	01 PEDESTAL C	1m X 0.4m X 0.9mH pedestal with concealed cabinet (see details)	1	set
8	02 PEDESTAL A	0.8m X 0.6m X 1mH pedestal with concealed cabinet (see details)	1	set
9	02 PEDESTAL B	0.8m X 0.4m X 0.8mH pedestal with concealed cabinet (see details)	1	set
10	02 PEDESTAL C	0.8m X 0.4m X 1.2mH pedestal with concealed cabinet (see details)	1	set
11	03 PEDESTAL A	1m X 0.4m X 1.1mH pedestal with concealed cabinet (see details)	1	set
12	03 PEDESTAL B	1m X 0.4m X 0.9mH pedestal with concealed cabinet (see details)	1	set
13	03 PEDESTAL C	1m X 0.4m X 0.9mH pedestal with concealed cabinet (see details)	1	set
14	04 PEDESTAL A	0.41m X 0.41m X 0.66mH pedestal with concealed cabinet (see details)	1	set
15	04 PEDESTAL B	0.41m X 0.41m X 0.8mH pedestal with concealed cabinet (see details)	1	set
16	04 PEDESTAL C	0.41m X 0.41m X 0.94mH pedestal with concealed cabinet (see details)	1	set
17	05 PEDESTAL A	1m X 0.4m X 1.1mH pedestal with concealed cabinet (see details)	1	set
18	05 PEDESTAL B	1m X 0.4m X 0.9mH pedestal with concealed cabinet (see details)	1	set
19	05 PEDESTAL C	1m X 0.4m X 0.9mH pedestal with concealed cabinet (see details)	1	set
20	06 PEDESTAL A	1m X 0.4m X 1.1mH pedestal with concealed cabinet (see details)	1	set
21	06 PEDESTAL B	1m X 0.4m X 0.9mH pedestal with concealed cabinet (see details)	1	set
22	06 PEDESTAL C	1m X 0.4m X 0.9mH pedestal with concealed cabinet (see details)	1	set
23	WHITE MANNEQUIN	FULL BODY MANNEQUIN	2	sets
24	RECEPTION COUNTER	1.6m X 0.4m X 1mH RECEPTION COUNTER with cupboard and SIDE PANEL (see details)	1	lot
25	DESIGN PHILIPPINES LOGO	3m X 0.1m X 0.5mH 3D CUT-OUT LETTERS	4	sets
26	DTI CITEM LOGO	0.55m X 0.1m X 0.2mH 3D CUT-OUT LETTERS	4	sets
27	MANILA FAME LOGO	0.94m X 0.1m X 0.5mH 3D CUT-OUT LETTERS	4	sets
28	COMPANY LOGO	Digital print sticker cut-out with matte lamination mounted on structure	1	lot
29	RECEPTION AREA GRAPHICS	Digital print sticker cut-out with matte lamination mounted on structure (1.5m X 2.7mH)	1	lot
30	REAR WALL GRAPHICS	Digital print sticker cut-out with matte lamination mounted on structure (0.9m X 2.7mH)	1	lot
31	TABLE AND CHAIR	4 SEATER TABLE WITH 4 CHAIR (see rendering)	7	sets
32	ELECTRICAL REQUIREMENT	electrical requirement for the pavilion including consumption (ingress, event proper, egress) 3-prong outlet with electrical consumption 15 sets (refer to design and technical drawings)	1	lot
33	LIGHTING REQUIREMENT	lighting requirement for the pavilion and products (spotlights) (refer to design and technical drawings)	1	lot
34	INSTALLATION OF HANGING PRODUCTS	Installation of hanging products of exhibitors (wall hang products, hanging lamps and decors)	1	lot
35	MOVING OF PRODUCT DISPLAY	Moving of product display to its preferred space or platform	1	lot
36	TENSION WIRES AND ACCESSORIES	100m TENSION WIRE with 100sets of U-lock and other appropriate accessories for installation of hanging lamps	1	lot

SEE TECHNICAL DRAWINGS FOR ACTUAL DETAILS

INCLUDE ELECTRICAL CONSUMPTION IN THE QUOTATION



INCLUDE ALL APPROPRIATE TAXES IN QUOTATION

	PROJECT:	TIGS 2024
	TITLE:	PHILIPPINE PAVILION
DESIGNED BY:	MSJ	LOCATION: TOKYO INTERNATIONAL EXHIBITION CENTER TOKYO, JAPAN
DATE/TIME:	08.02.24	SHEET CONTENT: CHECKLIST
		SHEET NO: 33

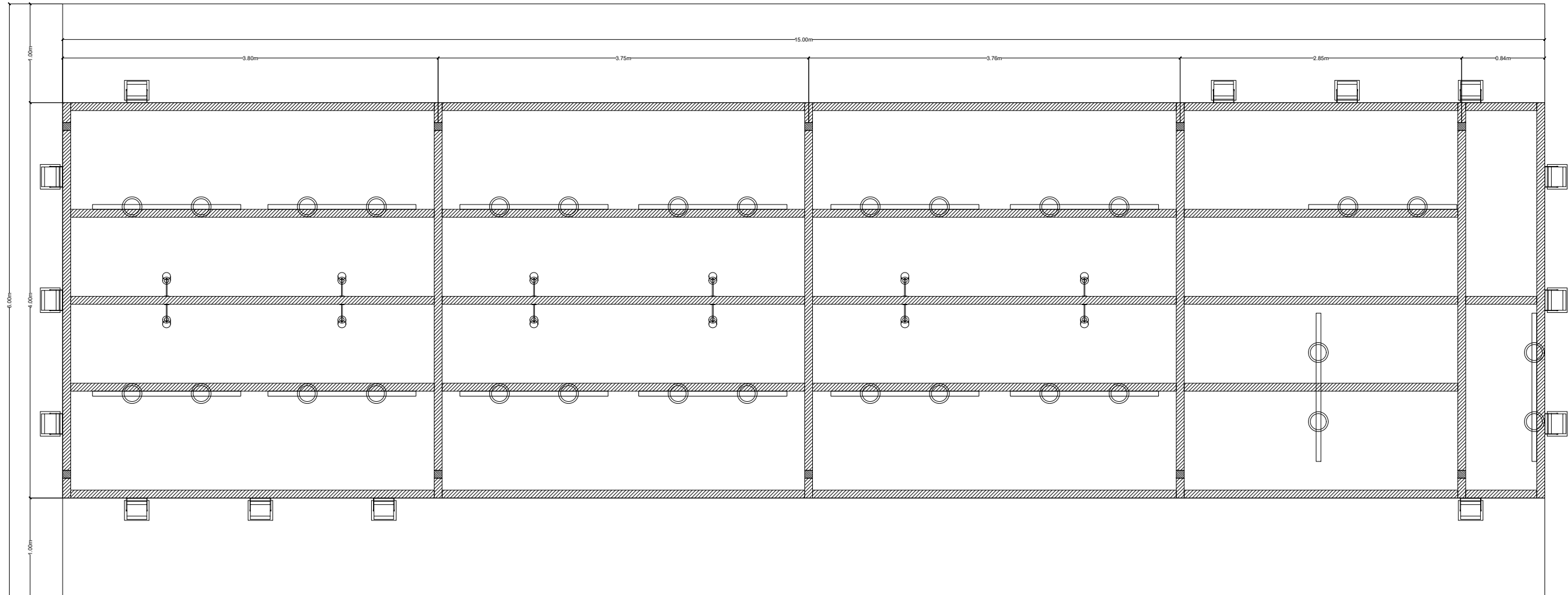
LIGHTING PLAN

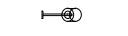

LEGEND:

- 
 12watts track light warm white 2 pcs with 1.5m Track bar per set in WHITE CASING
- 
 12watts long arm spotlight warm white in WHITE CASING
- 
 30watts flood light warm white in WHITE CASING (see rendering for color reference)

	PROJECT: TIGS 2024
	TITLE: PHILIPPINE PAVILION
DESIGNED BY: MSJ	LOCATION: TOKYO INTERNATIONAL EXHIBITION CENTER TOKYO, JAPAN
DATE/TIME: 07.29.24	SHEET CONTENT: LIGHTING PLAN
	SHEET NO.: 02

ELECTRICAL PLAN

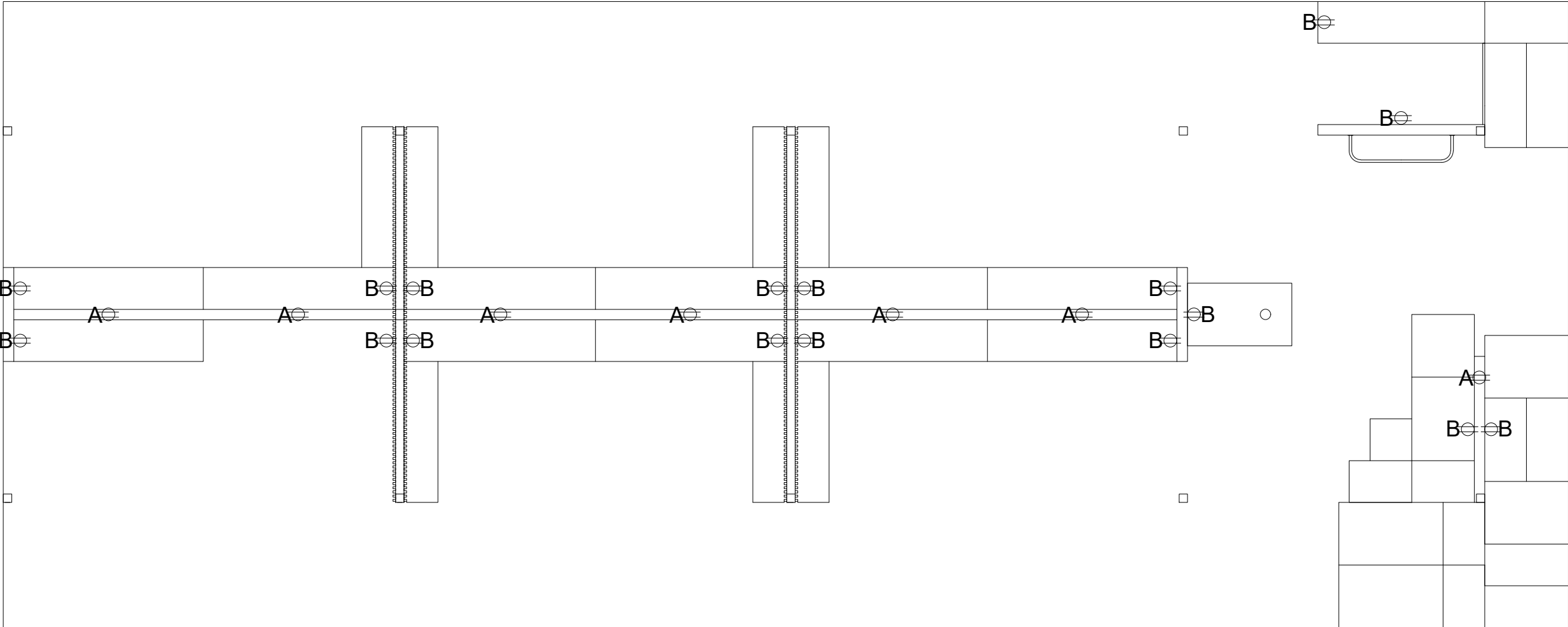

LEGEND:

B 3-GANG / 3-PRONG CONVENIENT OUTLET (11 SETS) MOUNTED ON WALL OR FLOOR EXTENSION

A 3-GANG / 3-PRONG CONVENIENT OUTLET (11 SETS) MOUNTED ON TOP OF BEAM (FOR HANGING LAMPS)

	PROJECT: TIGS 2024
	TITLE: PHILIPPINE PAVILION
DESIGNED BY: MSJ	LOCATION: TOKYO INTERNATIONAL EXHIBITION CENTER TOKYO, JAPAN
DATE/TIME: 07.29.24	SHEET CONTENT: ELECTRICAL PLAN
	SHEET NO: 03

FRONT ELEVATION

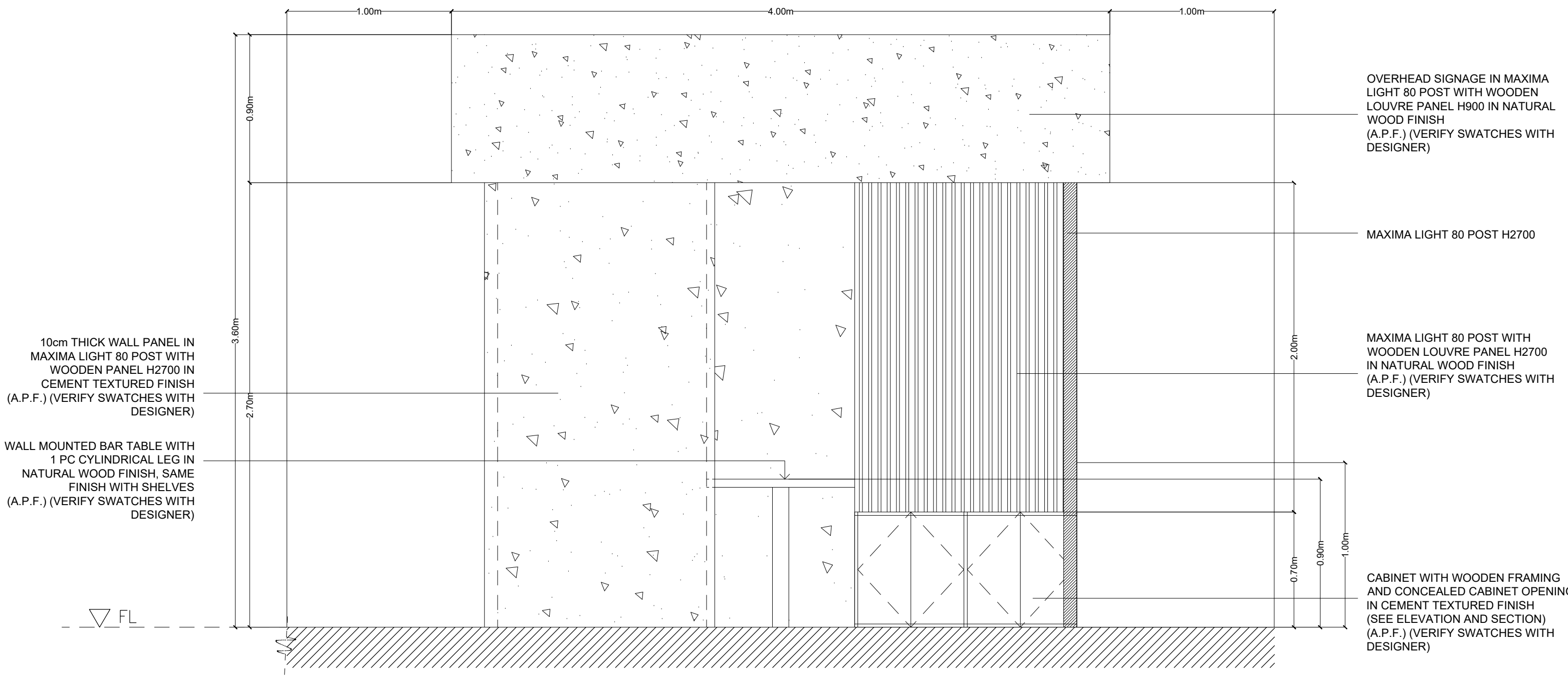

	PROJECT:	TIGS 2024	
	TITLE:	PHILIPPINE PAVILION	
DESIGNED BY:	MSJ	LOCATION:	
		TOKYO INTERNATIONAL EXHIBITION CENTER TOKYO, JAPAN	
DATE/TIME:	07.29.24	SHEET CONTENT:	SHEET NO.:
		FRONT ELEVATION	04

LEFT SIDE ELEVATION

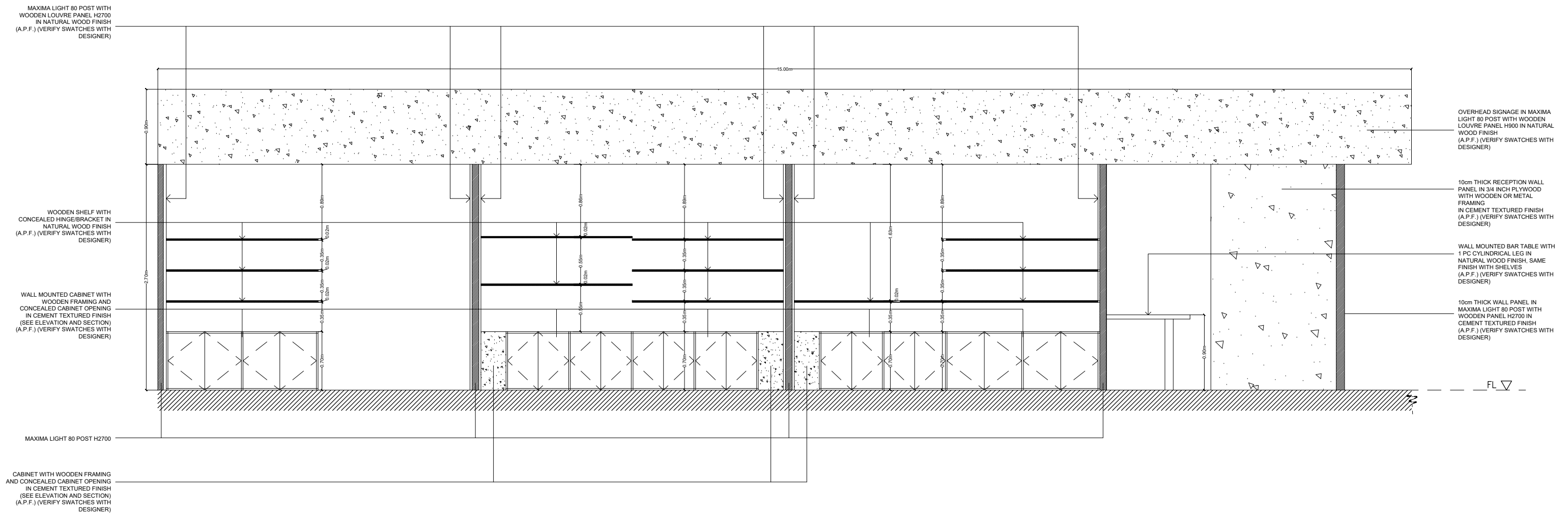

	PROJECT: TIGS 2024
	TITLE: PHILIPPINE PAVILION
DESIGNED BY: MSJ	LOCATION: TOKYO INTERNATIONAL EXHIBITION CENTER TOKYO, JAPAN
DATE/TIME: 07.29.24	SHEET CONTENT: LEFT SIDE ELVATION
	SHEET NO.: 05

RIGHT SIDE ELEVATION

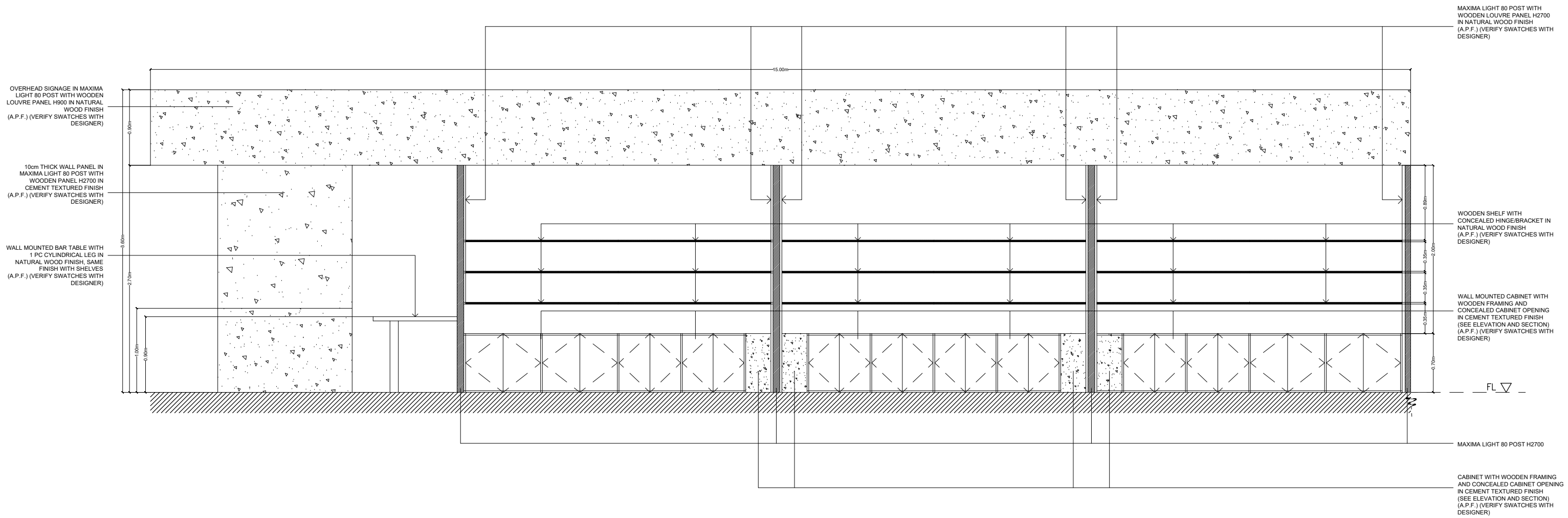

	PROJECT: TIGS 2024
	TITLE: PHILIPPINE PAVILION
DESIGNED BY: MSJ	LOCATION: TOKYO INTERNATIONAL EXHIBITION CENTER TOKYO, JAPAN
DATE/TIME: 07.29.24	SHEET CONTENT: RIGHT SIDE ELAVATION
	SHEET NO: 06

REAR ELEVATION

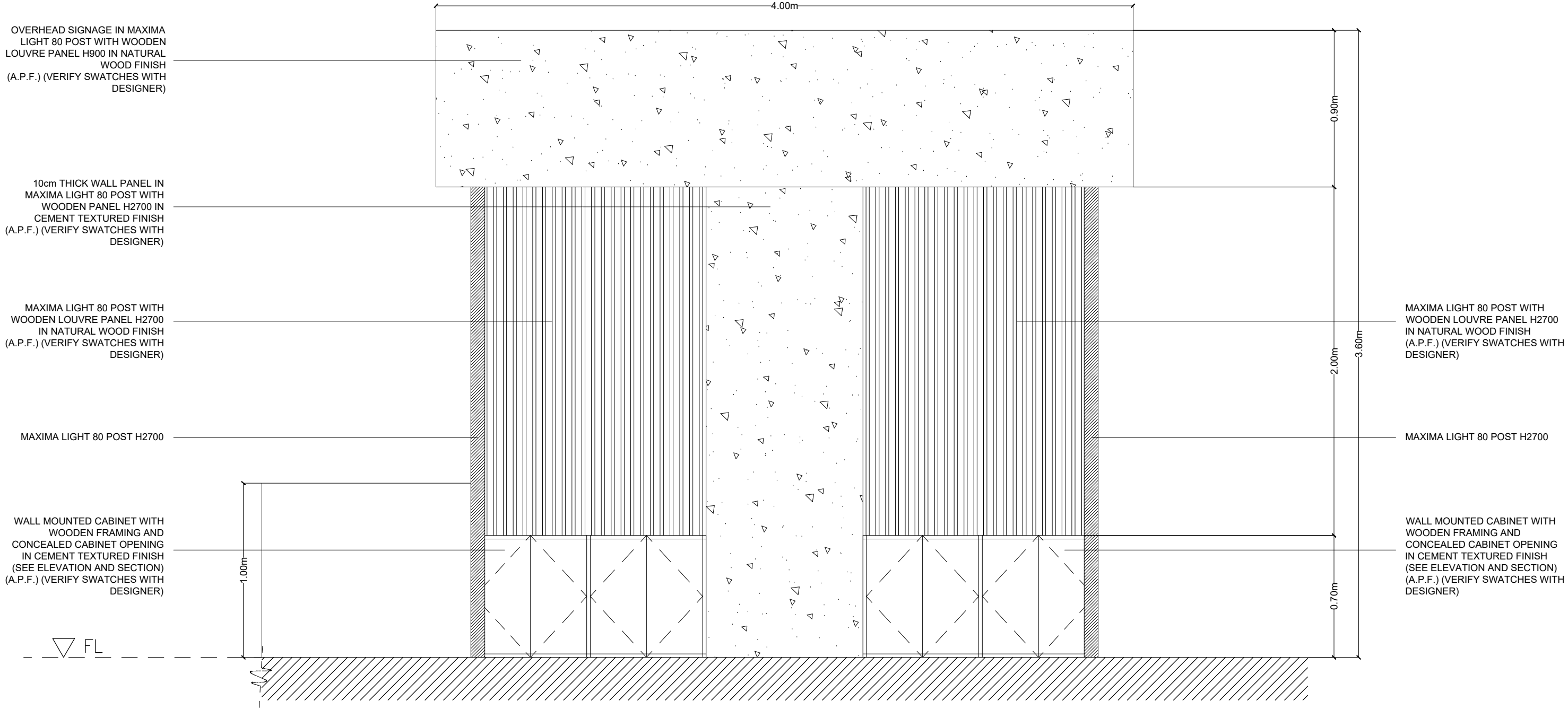

	PROJECT:	TIGS 2024
	TITLE:	PHILIPPINE PAVILION
DESIGNED BY:	MSJ	LOCATION:
		TOKYO INTERNATIONAL EXHIBITION CENTER TOKYO, JAPAN
DATE/TIME:	07.29.24	SHEET CONTENT:
		REAR ELEVATION
		SHEET NO.:
		07

SECTION A

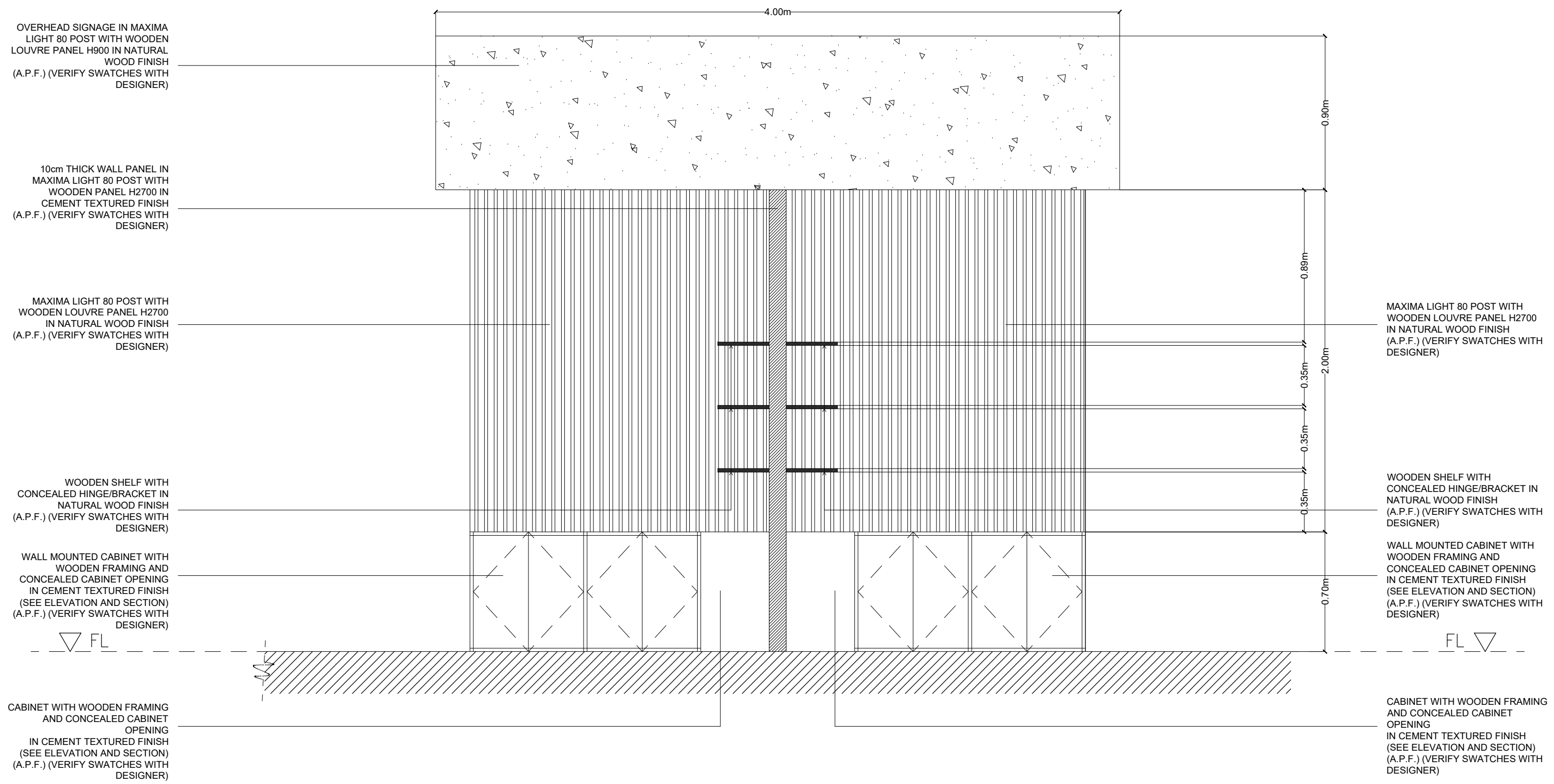

	PROJECT:	TIGS 2024
	TITLE:	PHILIPPINE PAVILION
DESIGNED BY:	MSJ	LOCATION:
		TOKYO INTERNATIONAL EXHIBITION CENTER TOKYO, JAPAN
DATE/TIME:	07.29.24	SHEET CONTENT:
		SECTION A
		SHEET NO:
		08

RECEPTION COUNTER DETAILS

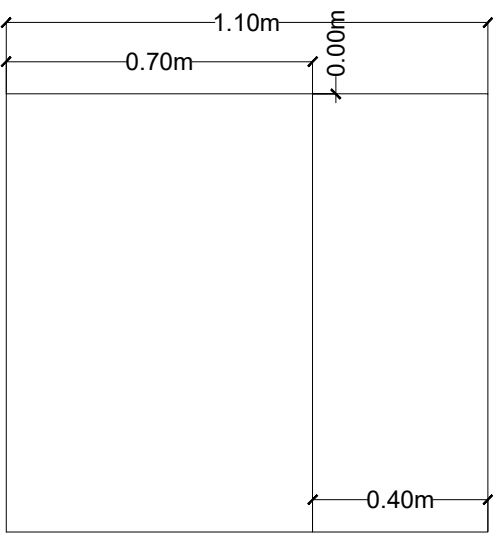
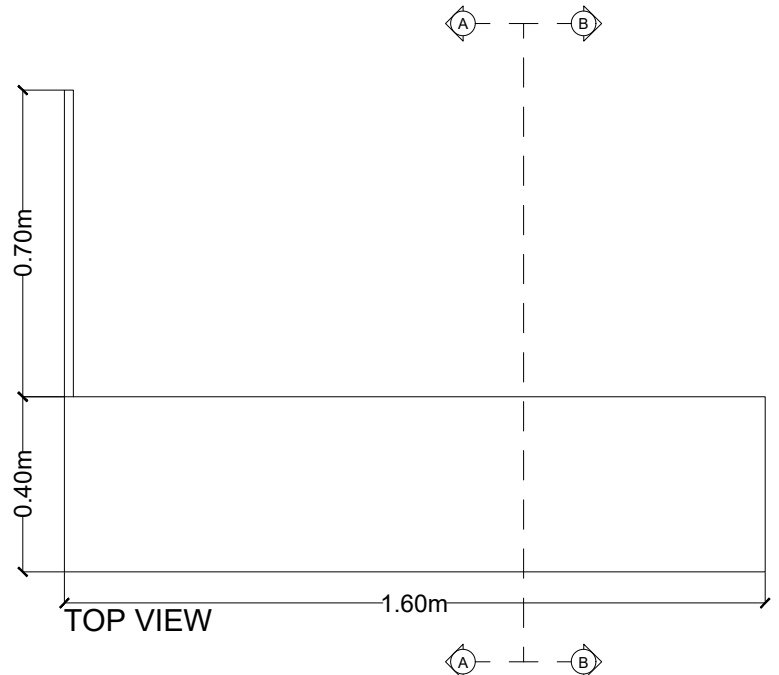

LEFT SIDE VIEW

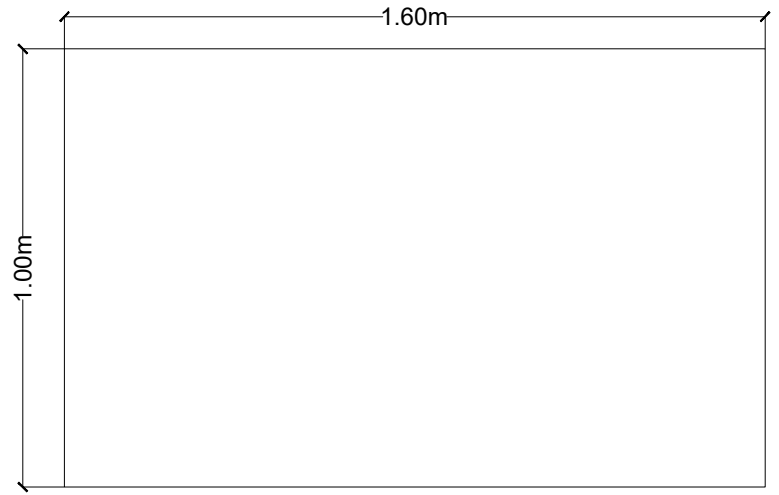

FRONT VIEW

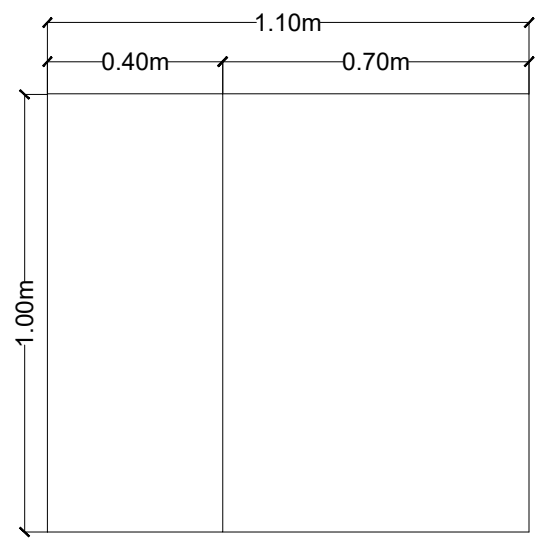

RIGHT SIDE VIEW

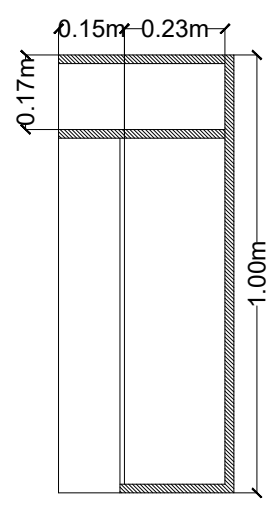

SECTION B

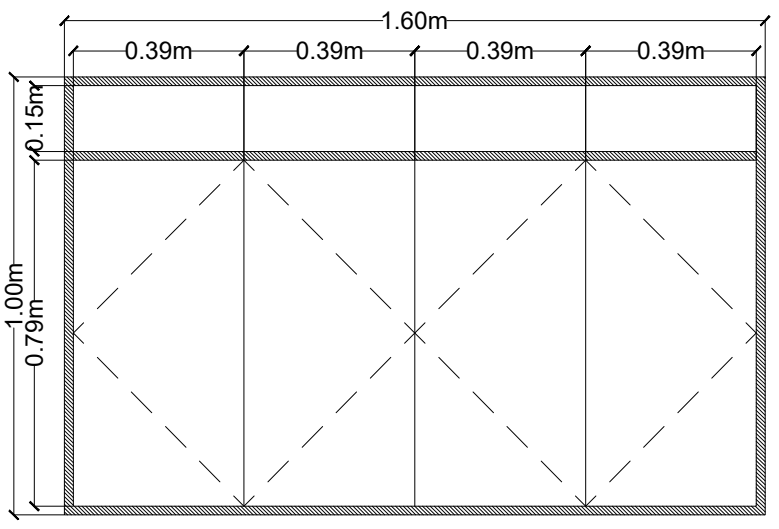

REAR VIEW

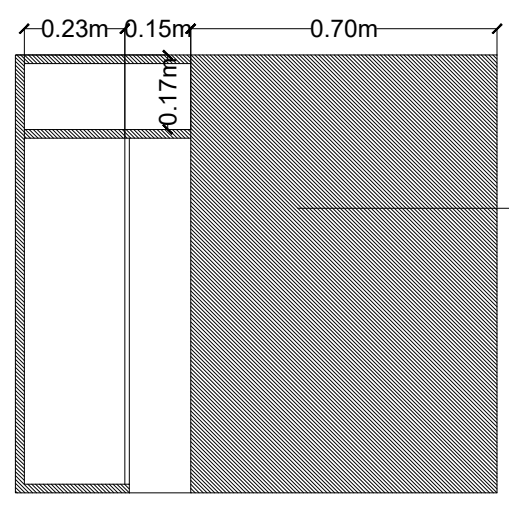

SECTION A

RECEPTION COUNTER SIDE
PANEL IN 3/4 INCH PLYWOOD IN
CEMENT TEXTURED FINISH
(A.P.F.) (VERIFY SWATCHES WITH
DESIGNER)

	PROJECT: TIGS 2024	
	TITLE: PHILIPPINE PAVILION	
DESIGNED BY: MSJ	LOCATION: TOKYO INTERNATIONAL EXHIBITION CENTER TOKYO, JAPAN	
DATE/TIME: 07.29.24	SHEET CONTENT: RECEPTION COUNTER	SHEET NO: 09

01 PEDESTAL A DETAILS

WITH CONCEALED CABINET
SAME FINISH WITH
CEMENT WALL FINISH

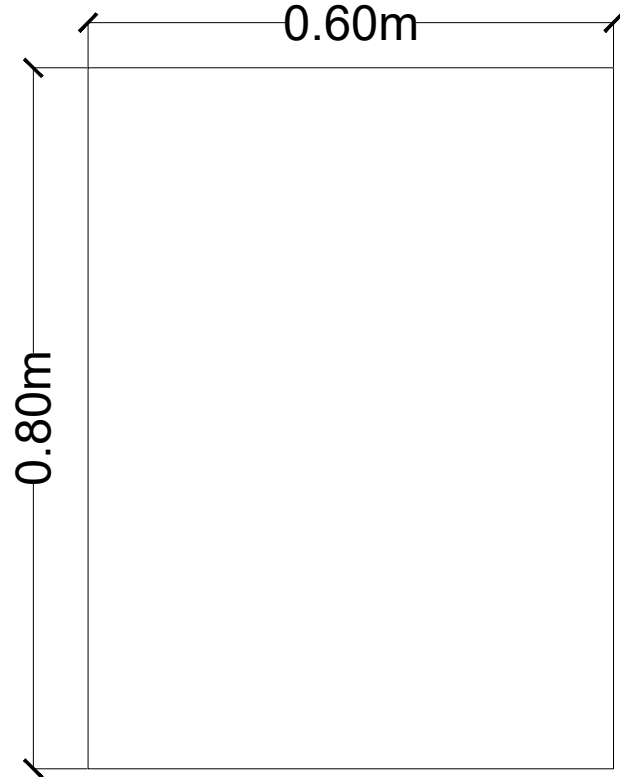

TOP VIEW

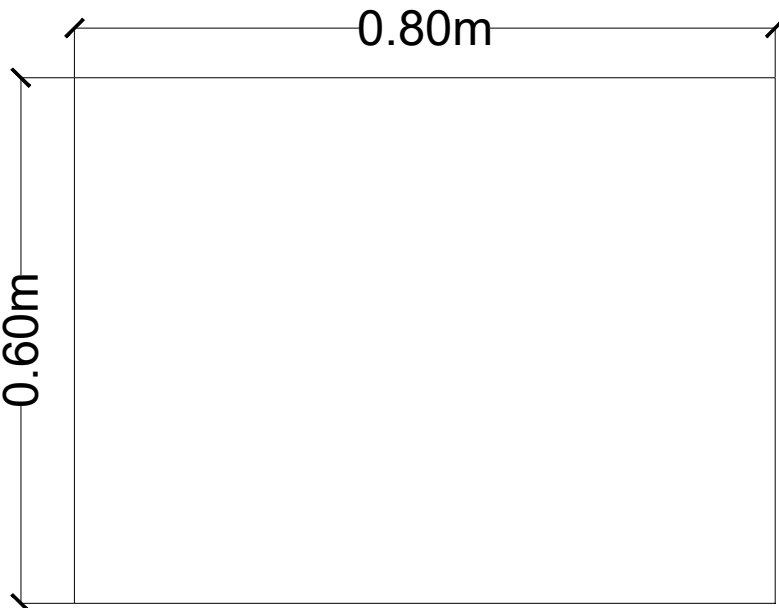

LEFT SIDE VIEW

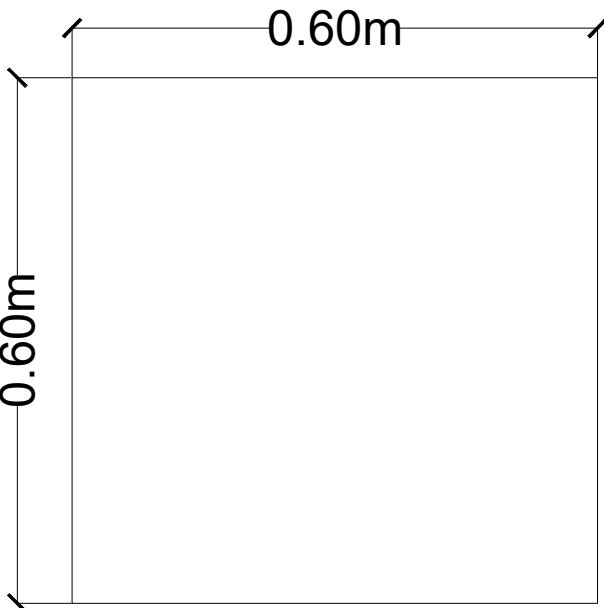

FRONT VIEW

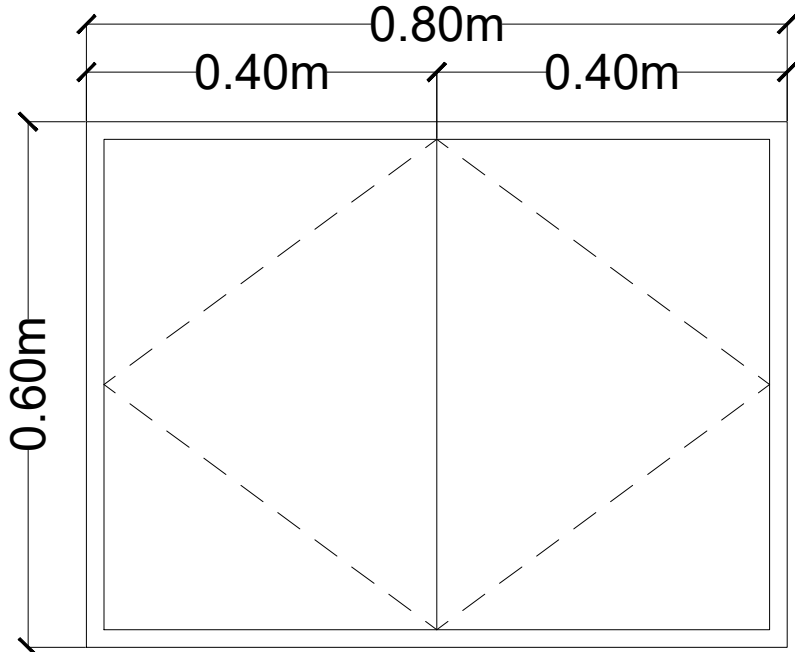

RIGHT SIDE VIEW

MATERIAL: 3/4 INCH PLYWOOD
WITH CEMENT PAINT FINISH

	PROJECT: TIGS 2024	
	TITLE: PHILIPPINE PAVILION	
DESIGNED BY: MSJ	LOCATION: TOKYO INTERNATIONAL EXHIBITION CENTER TOKYO, JAPAN	
DATE/TIME: 07.29.24	SHEET CONTENT: 01 PEDESTAL A	SHEET NO: 10

01 PEDESTAL B DETAILS

WITH CONCEALED CABINET
SAME FINISH WITH
CEMENT WALL FINISH

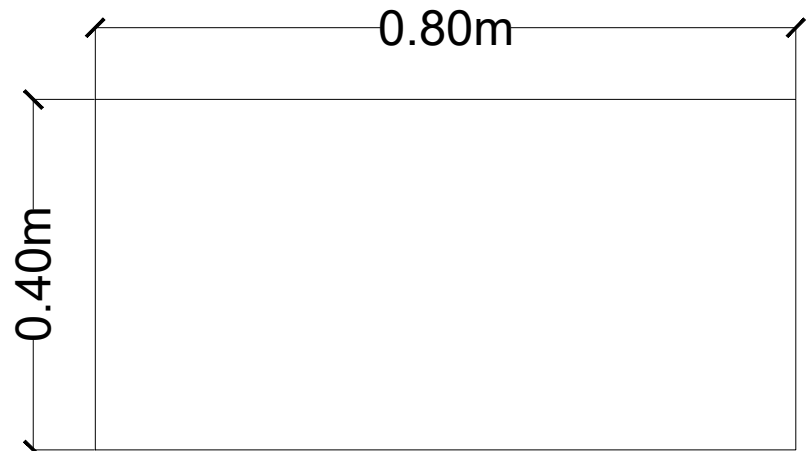

TOP VIEW

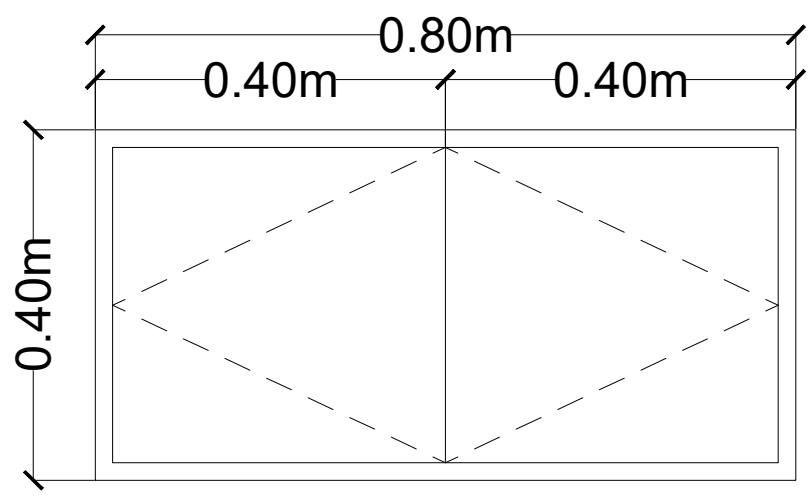

FRONT VIEW

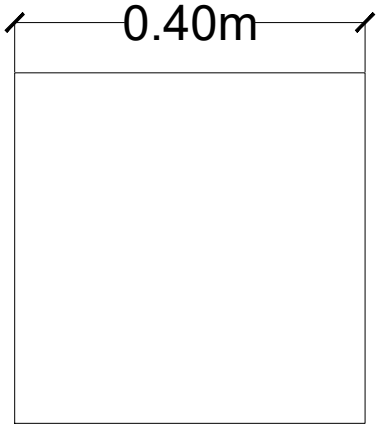

RIGHT SIDE VIEW

MATERIAL: 3/4 INCH PLYWOOD
WITH CEMENT PAINT FINISH

	PROJECT:	TIGS 2024	
	TITLE:	PHILIPPINE PAVILION	
DESIGNED BY:	MSJ	LOCATION:	
		TOKYO INTERNATIONAL EXHIBITION CENTER TOKYO, JAPAN	
DATE/TIME:	07.29.24	SHEET CONTENT:	SHEET NO.:
		01 PEDESTAL B	11

01 PEDESTAL C DETAILS

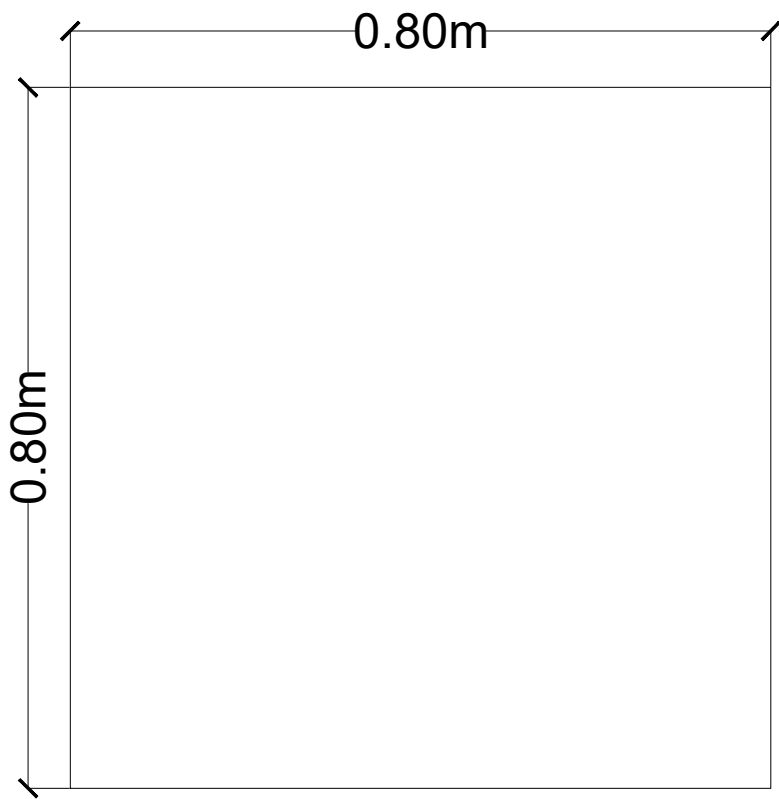
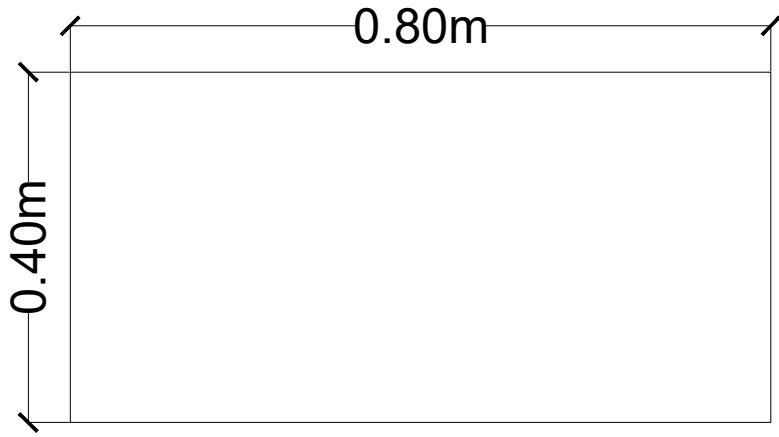

FRONT VIEW

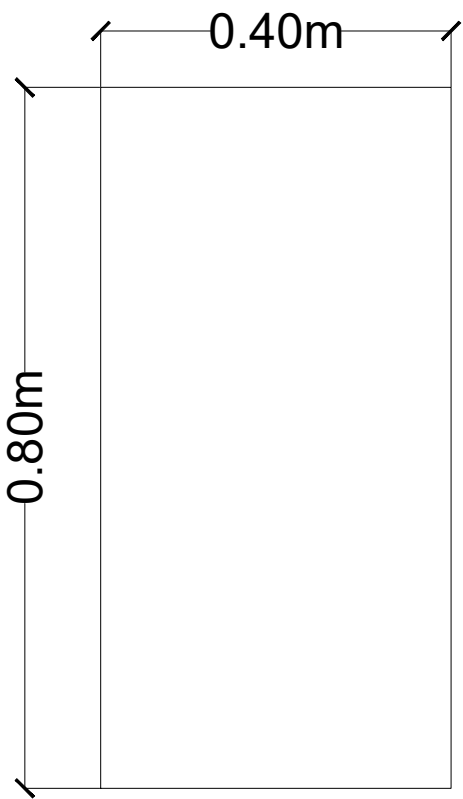

RIGHT SIDE VIEW

MATERIAL: 3/4 INCH PLYWOOD
WITH CEMENT PAINT FINISH

	PROJECT: TIGS 2024
	TITLE: PHILIPPINE PAVILION
DESIGNED BY: MSJ	LOCATION: TOKYO INTERNATIONAL EXHIBITION CENTER TOKYO, JAPAN
DATE/TIME: 07.29.24	SHEET CONTENT: 01 PEDESTAL C
	SHEET NO.: 12

02 PEDESTAL A DETAILS

WITH CONCEALED CABINET
SAME FINISH WITH
CEMENT WALL FINISH

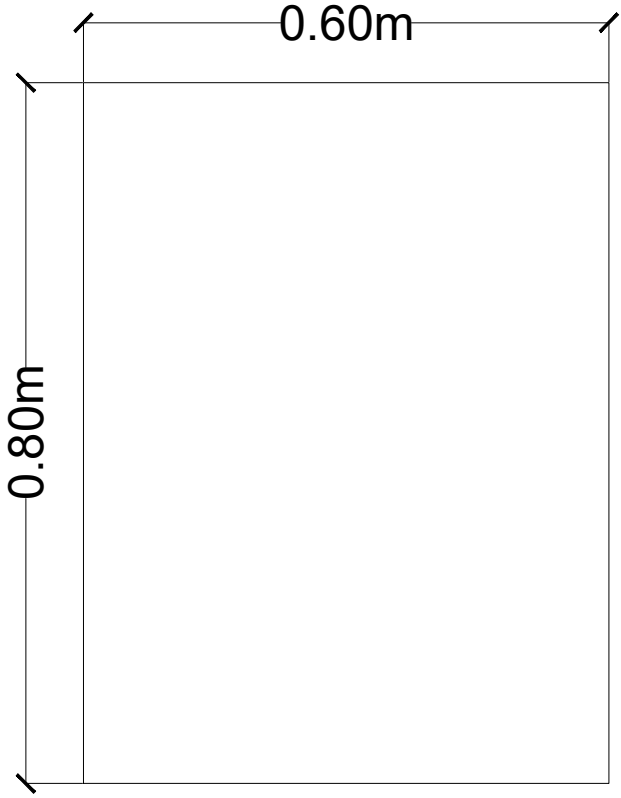

TOP VIEW

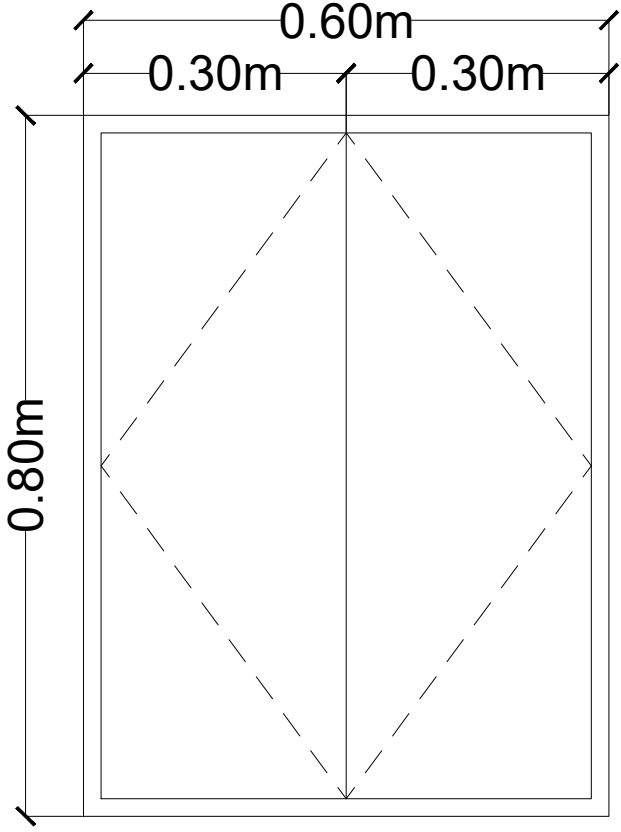

FRONT VIEW

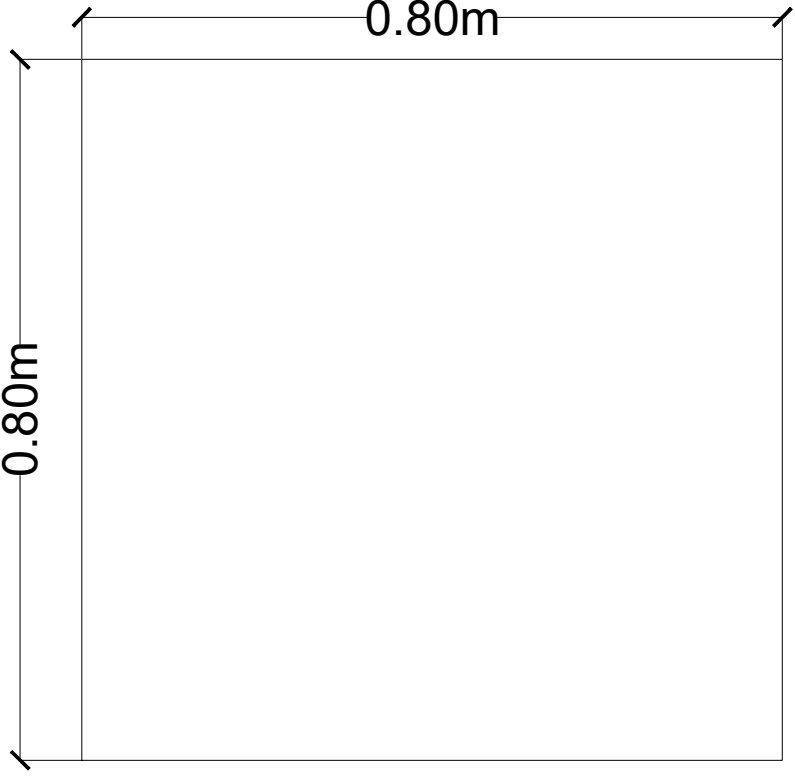

RIGHT SIDE VIEW

MATERIAL: 3/4 INCH PLYWOOD
WITH CEMENT PAINT FINISH

	PROJECT: TIGS 2024
	TITLE: PHILIPPINE PAVILION
DESIGNED BY: MSJ	LOCATION: TOKYO INTERNATIONAL EXHIBITION CENTER TOKYO, JAPAN
DATE/TIME: 07.29.24	SHEET CONTENT: 02 PEDESTAL A
	SHEET NO.: 13

02 PEDESTAL B DETAILS

WITH CONCEALED CABINET
SAME FINISH WITH
CEMENT WALL FINISH

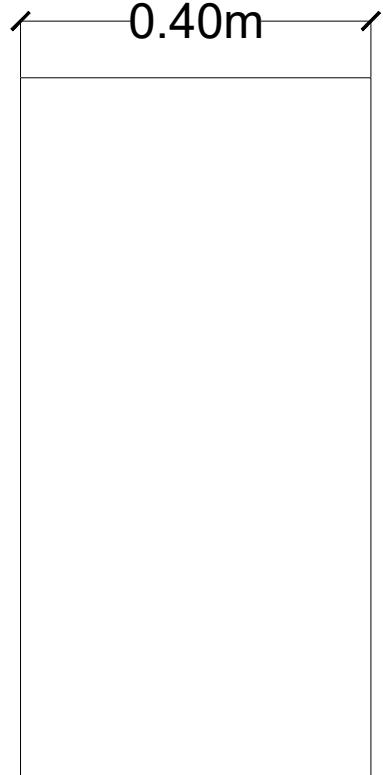

TOP VIEW

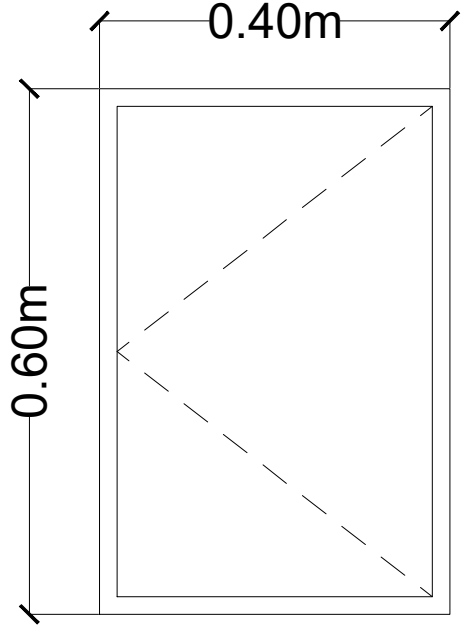

FRONT VIEW

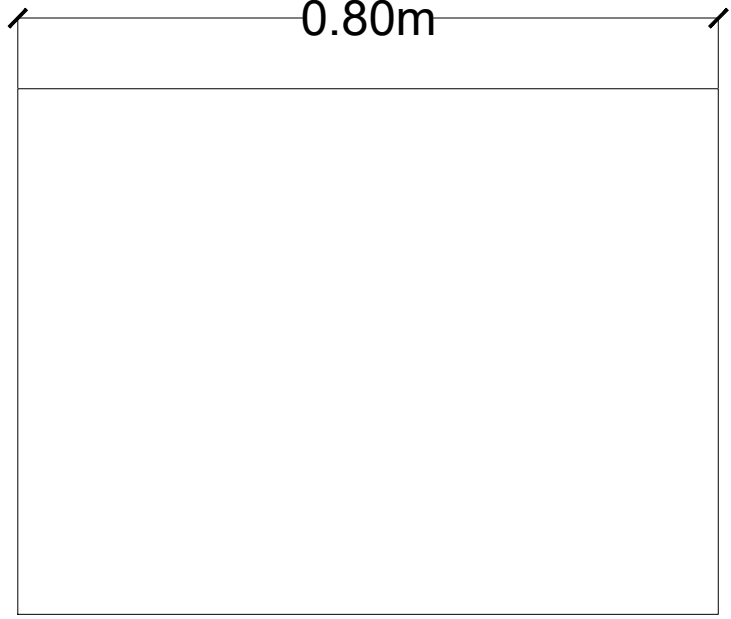

RIGHT SIDE VIEW

MATERIAL: 3/4 INCH PLYWOOD
WITH CEMENT PAINT FINISH

	PROJECT: TIGS 2024	
	TITLE: PHILIPPINE PAVILION	
DESIGNED BY: MSJ	LOCATION: TOKYO INTERNATIONAL EXHIBITION CENTER TOKYO, JAPAN	
DATE/TIME: 07.29.24	SHEET CONTENT: 02 PEDESTAL B	SHEET NO.: 14

02 PEDESTAL C DETAILS

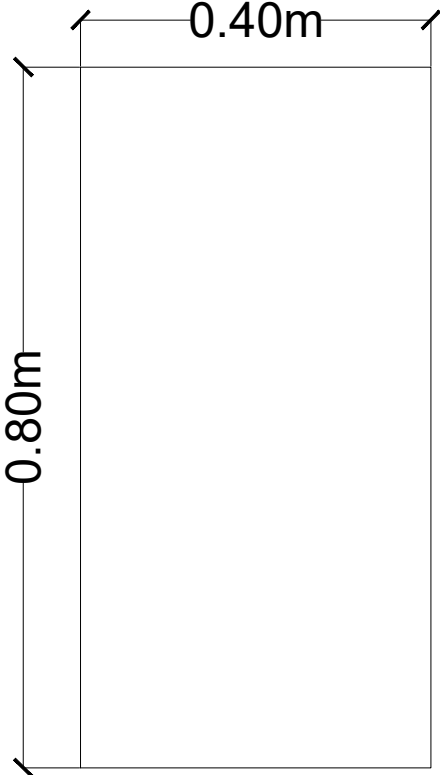

TOP VIEW

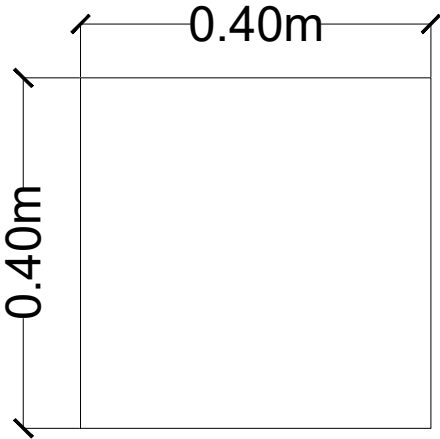

FRONT VIEW

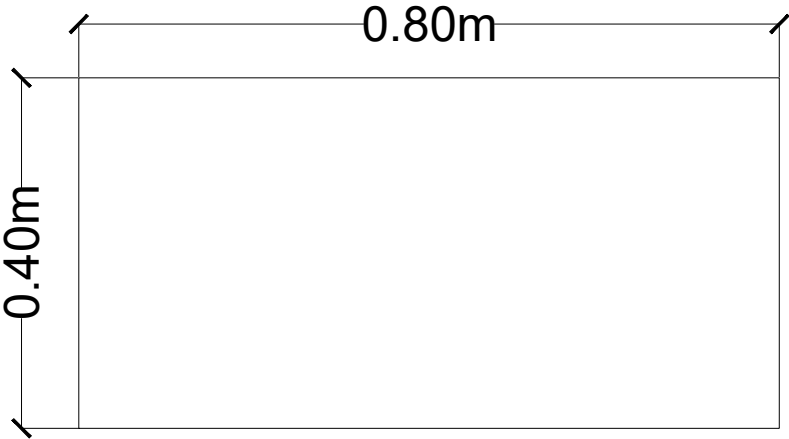

RIGHT SIDE VIEW

MATERIAL: 3/4 INCH PLYWOOD
WITH CEMENT PAINT FINISH

	PROJECT: TIGS 2024	
	TITLE: PHILIPPINE PAVILION	
DESIGNED BY: MSJ	LOCATION: TOKYO INTERNATIONAL EXHIBITION CENTER TOKYO, JAPAN	
DATE/TIME: 07.29.24	SHEET CONTENT: 02 PEDESTAL C	SHEET NO.: 15

03 PEDESTAL A DETAILS

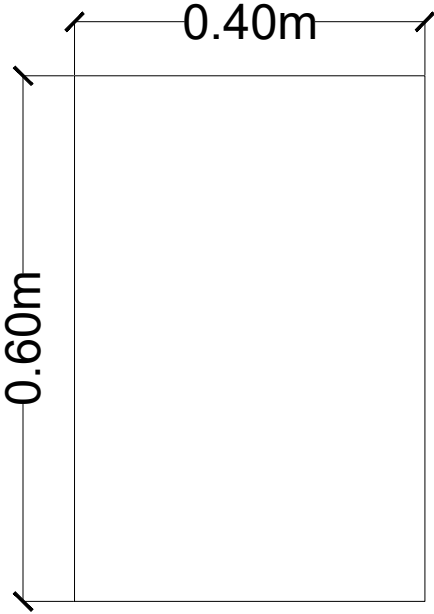

TOP VIEW

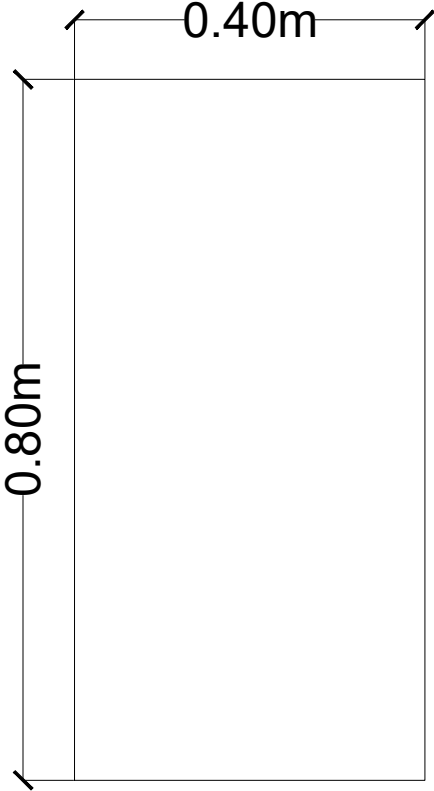

FRONT VIEW

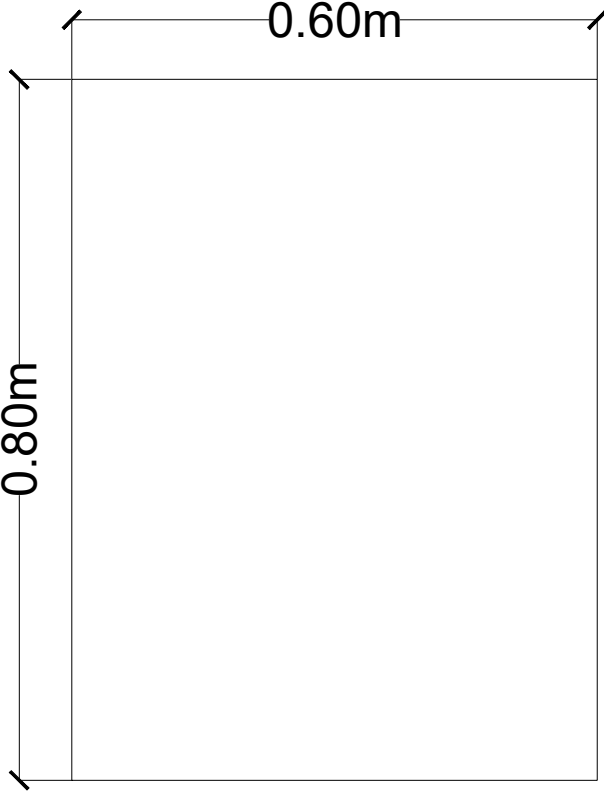

RIGHT SIDE VIEW

MATERIAL: 3/4 INCH PLYWOOD
WITH CEMENT PAINT FINISH

	<small>PROJECT:</small> TIGS 2024
	<small>TITLE:</small> PHILIPPINE PAVILION
	<small>LOCATION:</small> TOKYO INTERNATIONAL EXHIBITION CENTER TOKYO, JAPAN
<small>DESIGNED BY:</small> MSJ	<small>DATE/TIME:</small> 07.29.24
<small>SHEET CONTENT:</small> 03 PEDESTAL A	<small>SHEET NO.:</small> 16

03 PEDESTAL B DETAILS

WITH CONCEALED CABINET
SAME FINISH WITH
CEMENT WALL FINISH

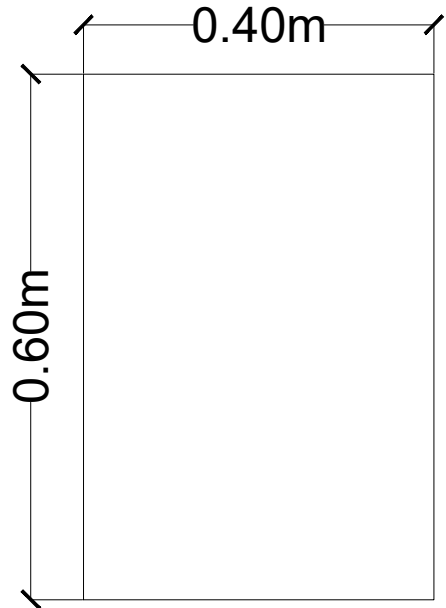

TOP VIEW

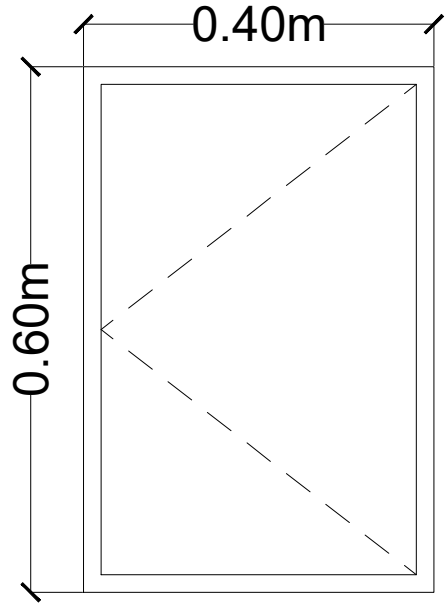

FRONT VIEW

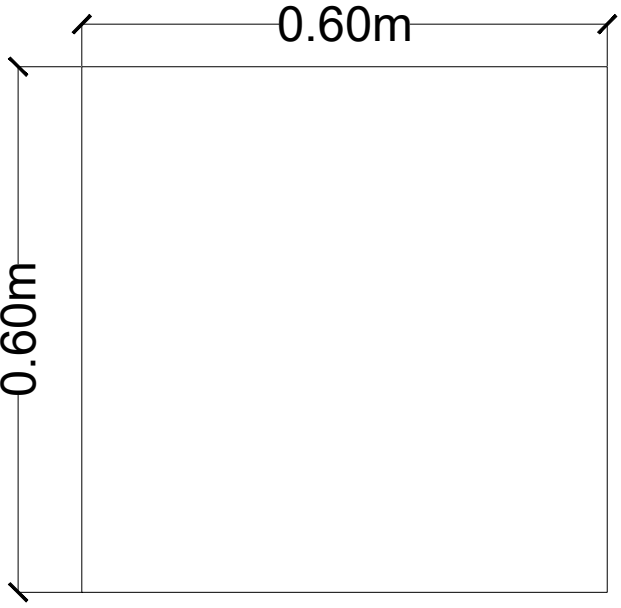

RIGHT SIDE VIEW

MATERIAL: 3/4 INCH PLYWOOD
WITH CEMENT PAINT FINISH

	PROJECT: TIGS 2024
	TITLE: PHILIPPINE PAVILION
DESIGNED BY: MSJ	LOCATION: TOKYO INTERNATIONAL EXHIBITION CENTER TOKYO, JAPAN
DATE/TIME: 07.29.24	SHEET CONTENT: 03 PEDESTAL B
	SHEET NO: 17

03 PEDESTAL C DETAILS

WITH CONCEALED CABINET
SAME FINISH WITH
CEMENT WALL FINISH

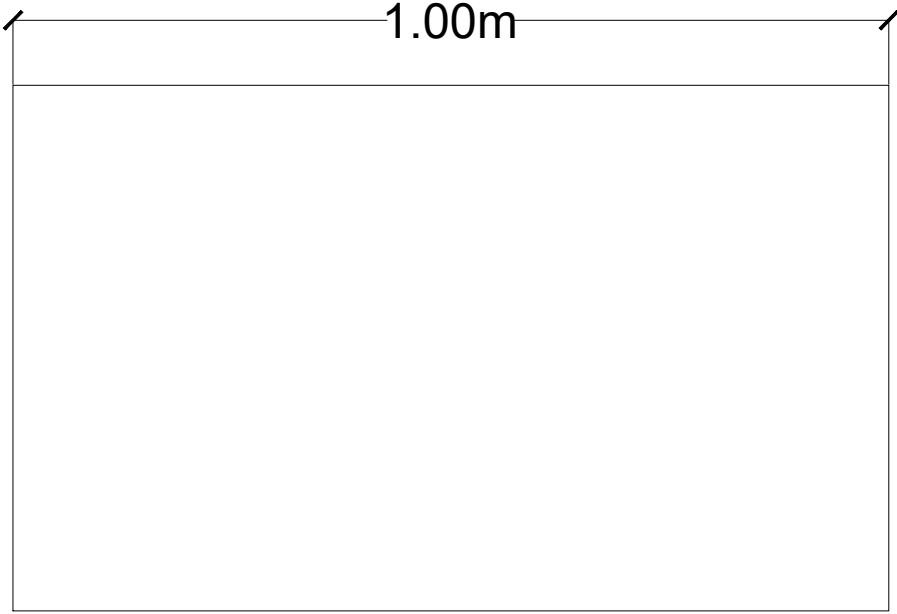

TOP VIEW

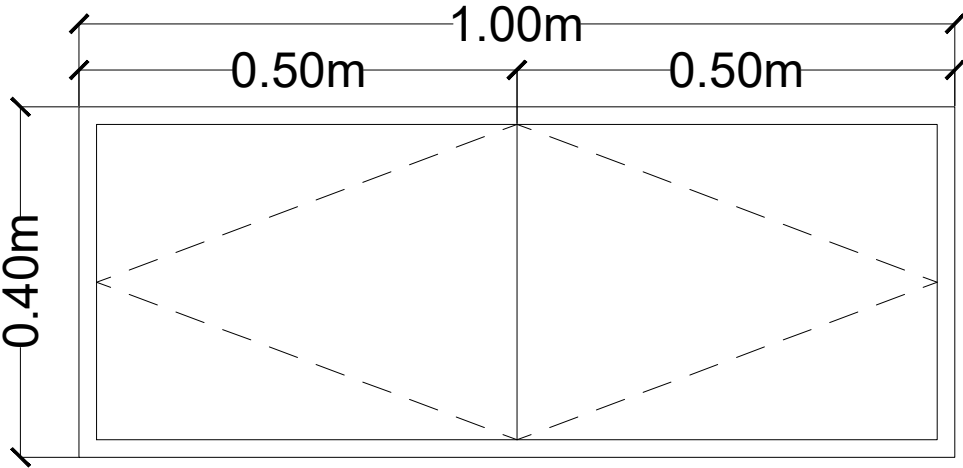

FRONT VIEW

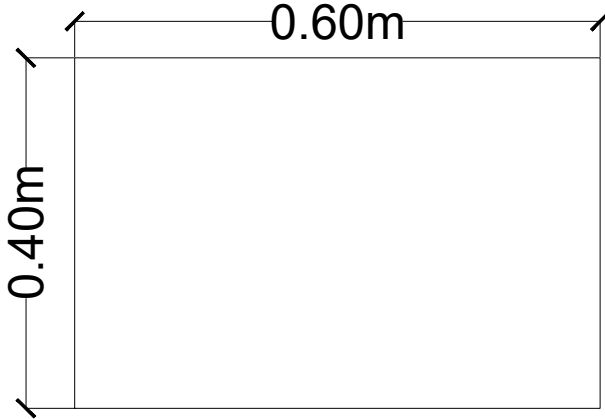

RIGHT SIDE VIEW

MATERIAL: 3/4 INCH PLYWOOD
WITH CEMENT PAINT FINISH

	PROJECT:	TIGS 2024
	TITLE:	PHILIPPINE PAVILION
DESIGNED BY:	MSJ	LOCATION:
DATE/TIME:	07.29.24	TOKYO INTERNATIONAL EXHIBITION CENTER TOKYO, JAPAN
SHEET CONTENT:		SHEET NO.:
03 PEDESTAL C		18

04 PEDESTAL A DETAILS

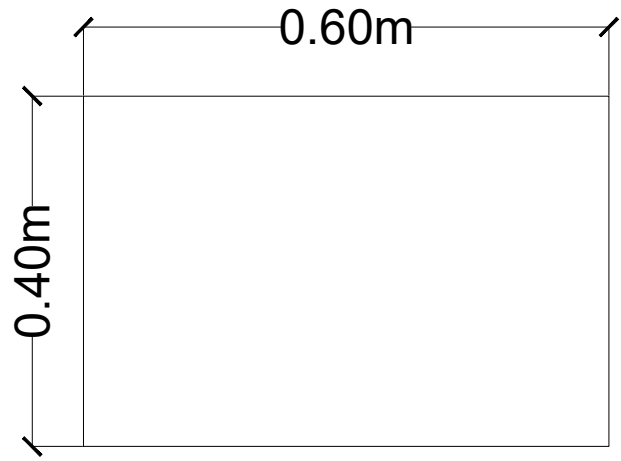

TOP VIEW

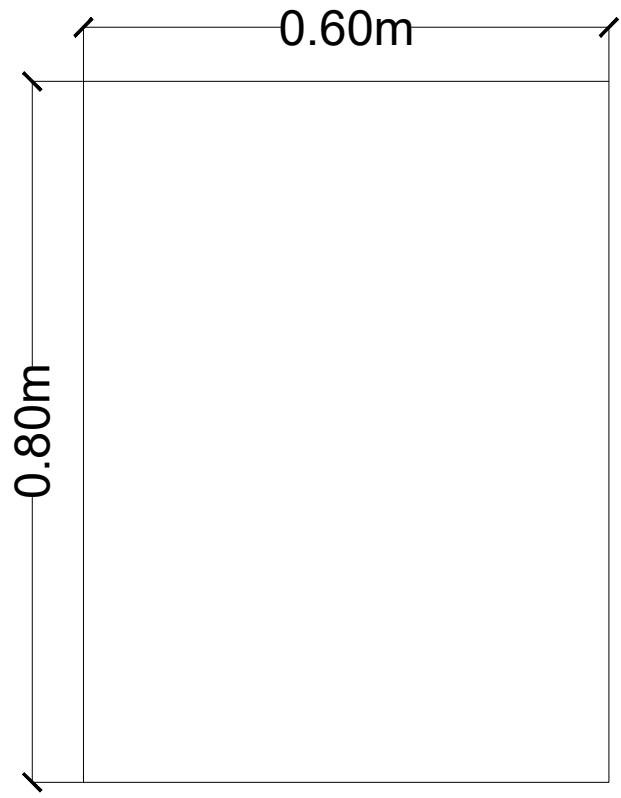

FRONT VIEW

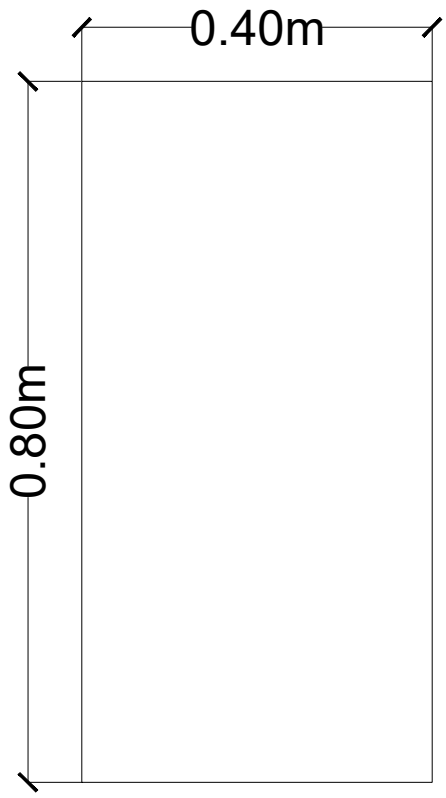

RIGHT SIDE VIEW

MATERIAL: 3/4 INCH PLYWOOD
WITH CEMENT PAINT FINISH

	<small>PROJECT:</small> TIGS 2024
	<small>TITLE:</small> PHILIPPINE PAVILION
	<small>DESIGNED BY:</small> MSJ
<small>DATE/TIME:</small> 07.29.24	<small>LOCATION:</small> TOKYO INTERNATIONAL EXHIBITION CENTER TOKYO, JAPAN
<small>DATE/TIME:</small> 07.29.24	<small>SHEET CONTENT:</small> 04 PEDESTAL A
	<small>SHEET NO.:</small> 19

04 PEDESTAL B DETAILS

WITH CONCEALED CABINET
SAME FINISH WITH
CEMENT WALL FINISH

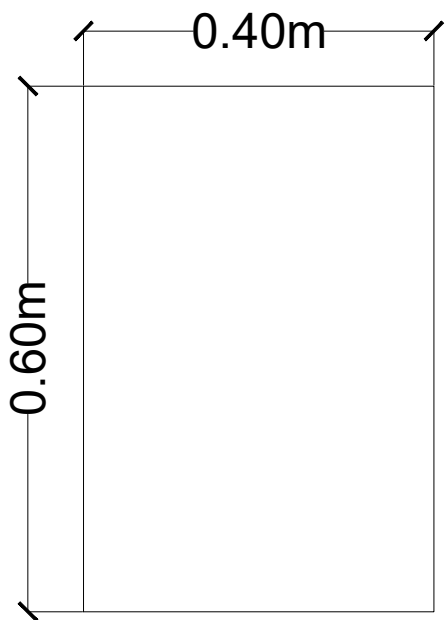

TOP VIEW

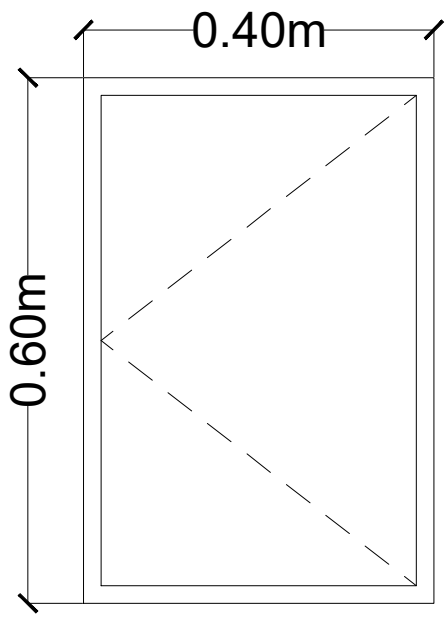

FRONT VIEW

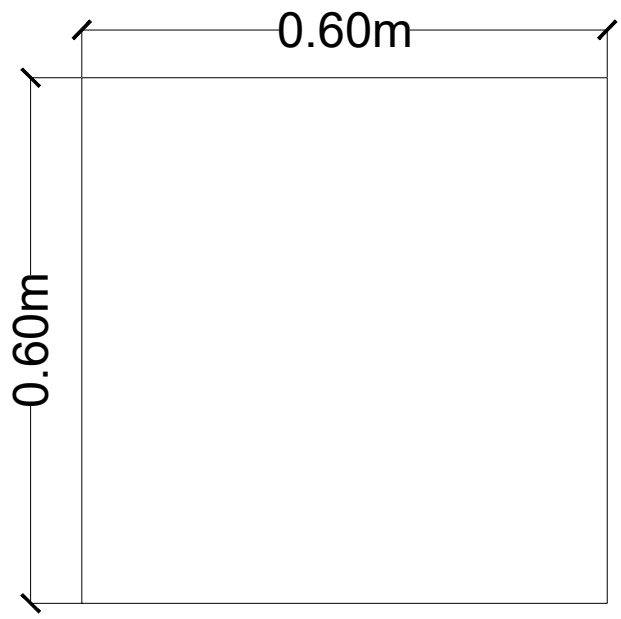

RIGHT SIDE VIEW

MATERIAL: 3/4 INCH PLYWOOD
WITH CEMENT PAINT FINISH

	PROJECT: TIGS 2024	
	TITLE: PHILIPPINE PAVILION	
DESIGNED BY: MSJ	LOCATION: TOKYO INTERNATIONAL EXHIBITION CENTER TOKYO, JAPAN	
DATE/TIME: 07.29.24	SHEET CONTENT: 04 PEDESTAL B	SHEET NO.: 20

04 PEDESTAL C DETAILS

WITH CONCEALED CABINET
SAME FINISH WITH
CEMENT WALL FINISH

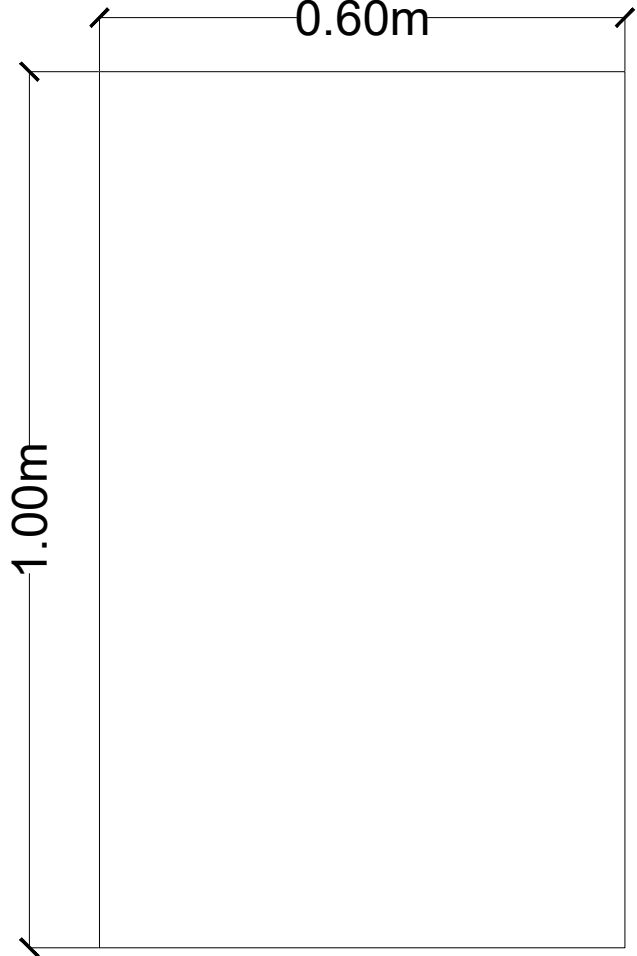

TOP VIEW

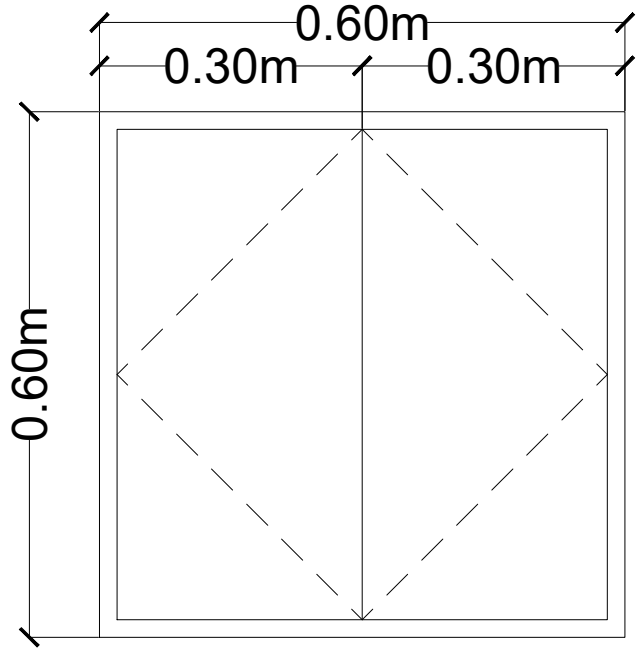

FRONT VIEW

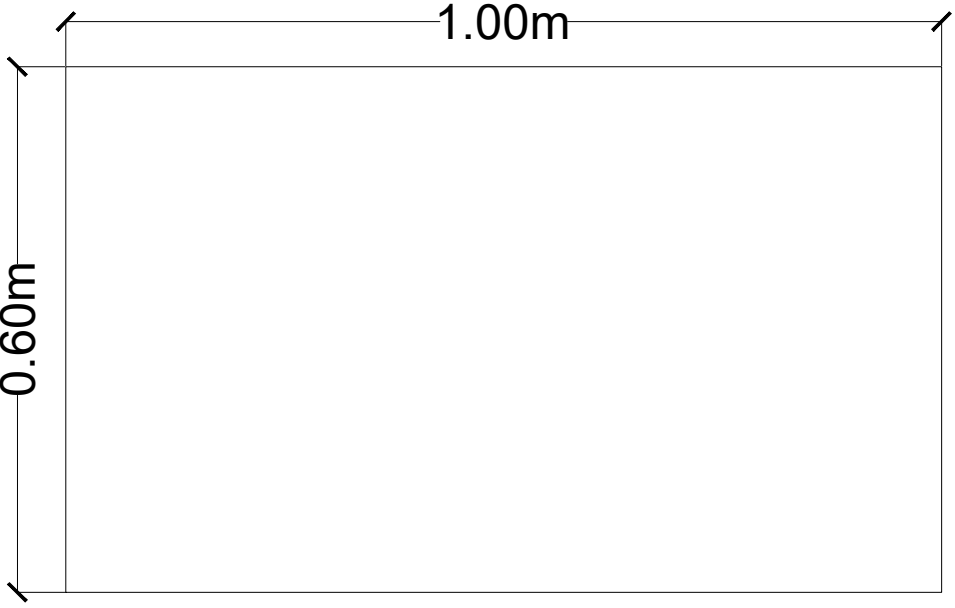

RIGHT SIDE VIEW

MATERIAL: 3/4 INCH PLYWOOD
WITH CEMENT PAINT FINISH

	PROJECT:	TIGS 2024
	TITLE:	PHILIPPINE PAVILION
DESIGNED BY:	MSJ	LOCATION:
DATE/TIME:	07.29.24	TOKYO INTERNATIONAL EXHIBITION CENTER TOKYO, JAPAN
	SHEET CONTENT:	SHEET NO.:
	04 PEDESTAL C	21

05 PEDESTAL A DETAILS

WITH CONCEALED CABINET
SAME FINISH WITH
CEMENT WALL FINISH

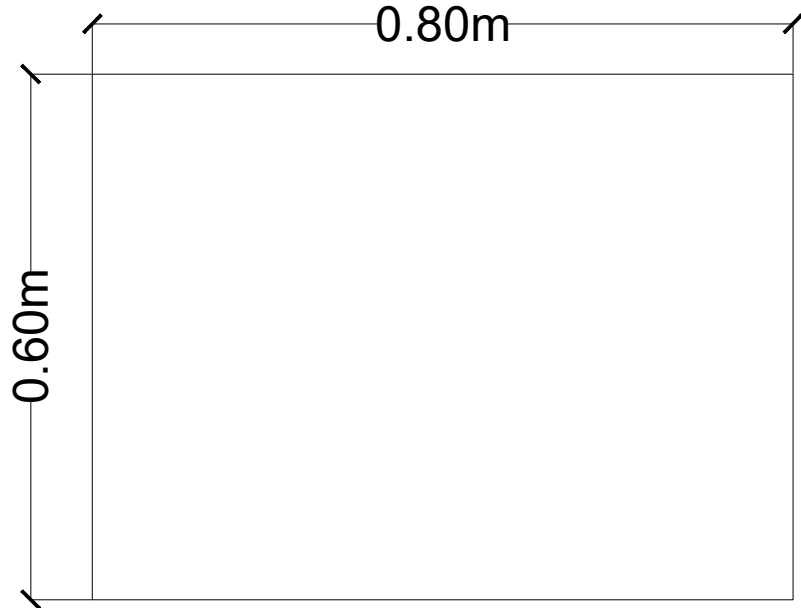

TOP VIEW

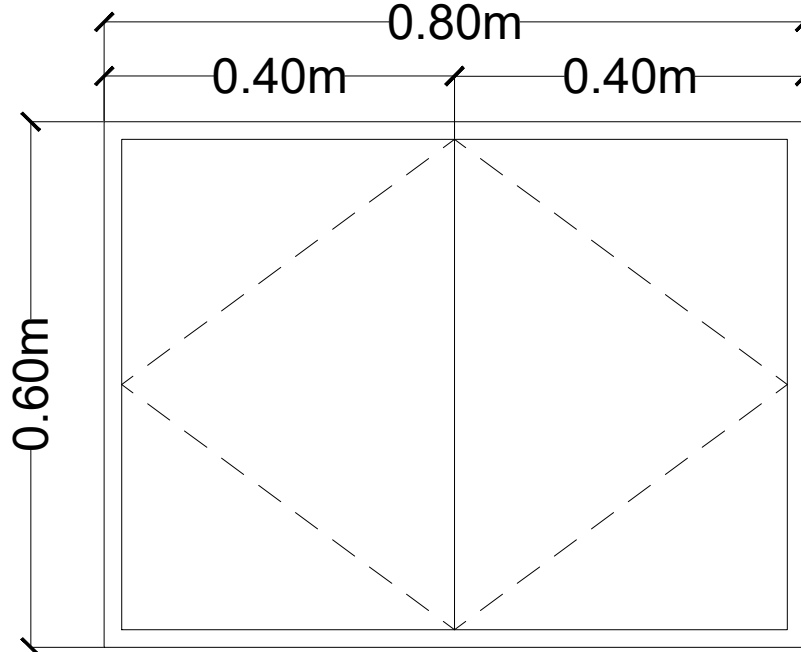

FRONT VIEW

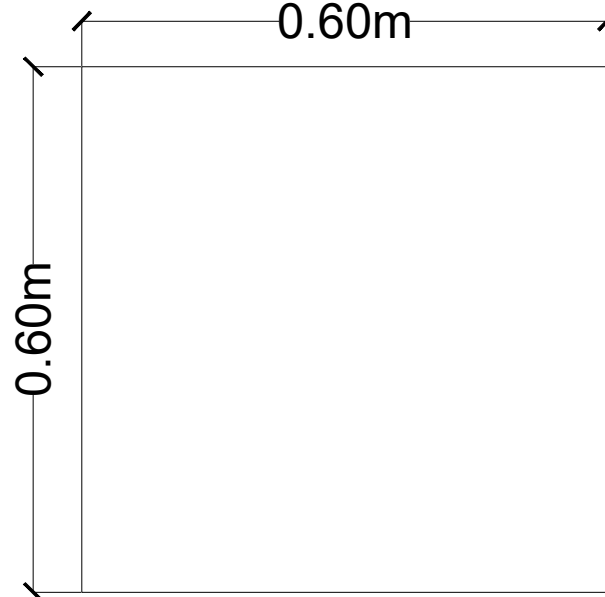

RIGHT SIDE VIEW

MATERIAL: 3/4 INCH PLYWOOD
WITH CEMENT PAINT FINISH

	PROJECT:	TIGS 2024	
	TITLE:	PHILIPPINE PAVILION	
DESIGNED BY:	MSJ	LOCATION:	
		TOKYO INTERNATIONAL EXHIBITION CENTER TOKYO, JAPAN	
DATE/TIME:	07.29.24	SHEET CONTENT:	SHEET NO:
		05 PEDESTAL A	22

05 PEDESTAL B DETAILS

WITH CONCEALED CABINET
SAME FINISH WITH
CEMENT WALL FINISH

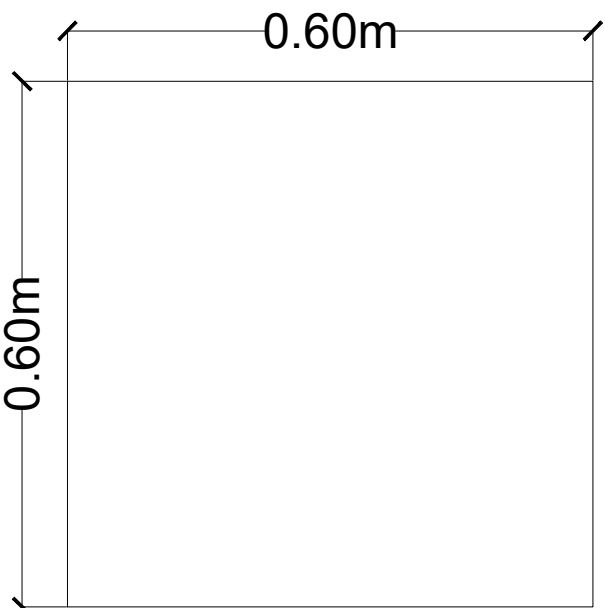

TOP VIEW

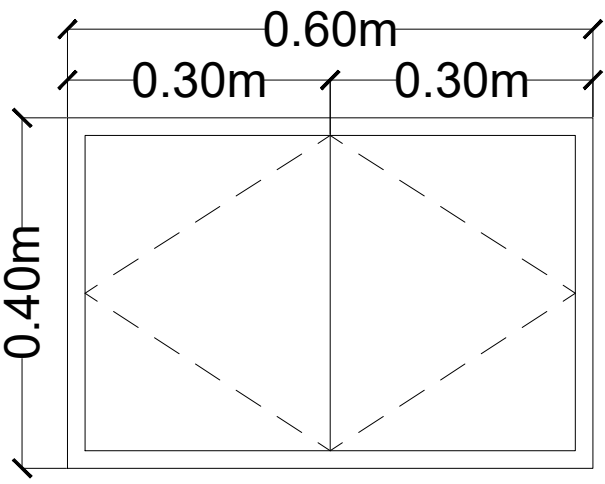

FRONT VIEW

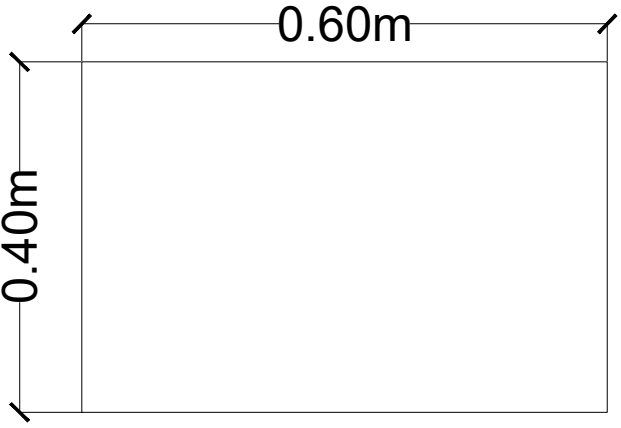

RIGHT SIDE VIEW

MATERIAL: 3/4 INCH PLYWOOD
WITH CEMENT PAINT FINISH

	PROJECT: TIGS 2024
	TITLE: PHILIPPINE PAVILION
DESIGNED BY: MSJ	LOCATION: TOKYO INTERNATIONAL EXHIBITION CENTER TOKYO, JAPAN
DATE/TIME: 07.29.24	SHEET CONTENT: 05 PEDESTAL B
	SHEET NO: 23

05 PEDESTAL C DETAILS

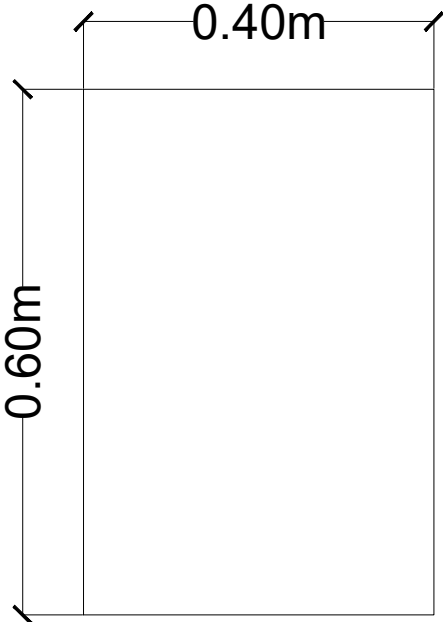

TOP VIEW

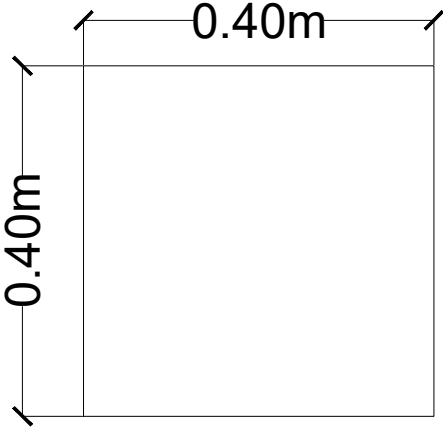

FRONT VIEW

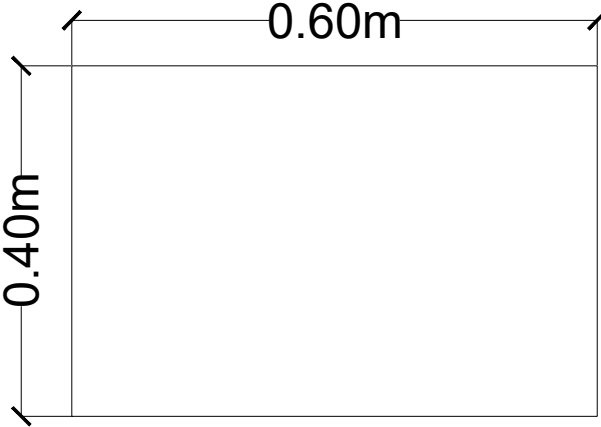

RIGHT SIDE VIEW

MATERIAL: 3/4 INCH PLYWOOD
WITH CEMENT PAINT FINISH

	PROJECT: TIGS 2024
	TITLE: PHILIPPINE PAVILION
DESIGNED BY: MSJ	LOCATION: TOKYO INTERNATIONAL EXHIBITION CENTER TOKYO, JAPAN
DATE/TIME: 07.29.24	SHEET CONTENT: 05 PEDESTAL C
	SHEET NO.: 24

06 PEDESTAL A DETAILS

WITH CONCEALED CABINET
SAME FINISH WITH
CEMENT WALL FINISH

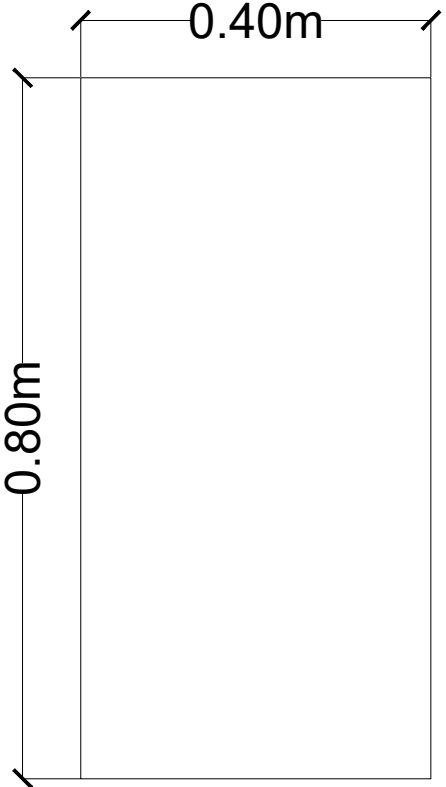

TOP VIEW

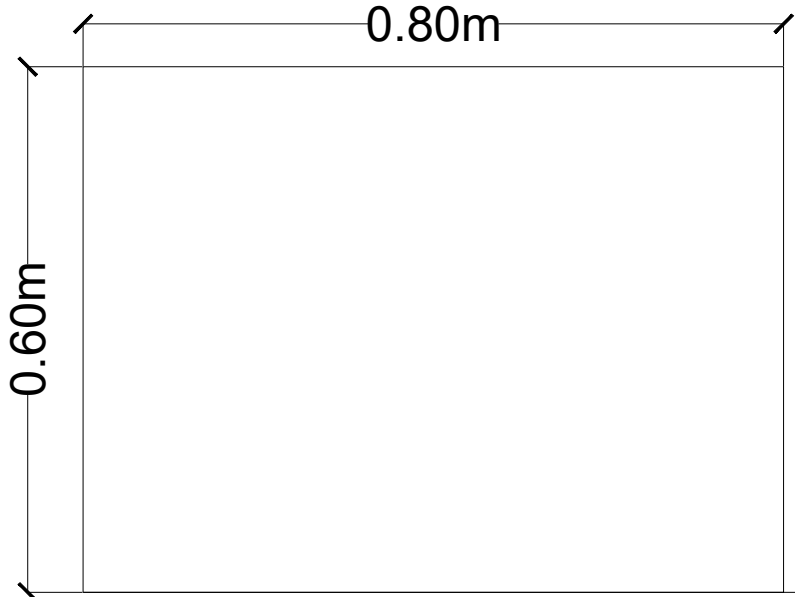

LEFT SIDE VIEW

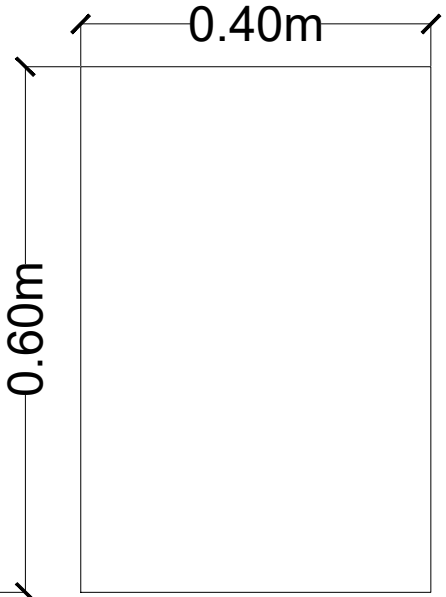

FRONT VIEW

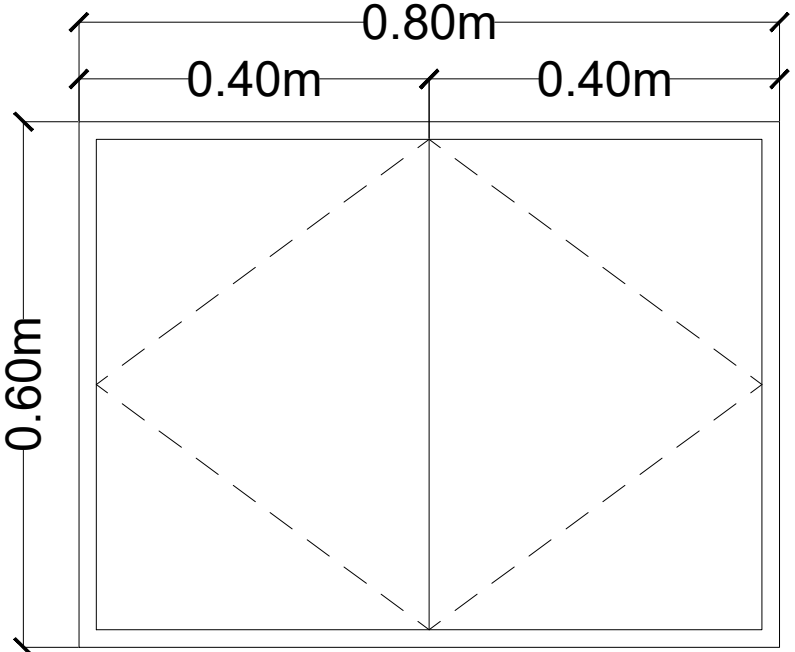

RIGHT SIDE VIEW

MATERIAL: 3/4 INCH PLYWOOD
WITH CEMENT PAINT FINISH

	PROJECT:	TIGS 2024
	TITLE:	PHILIPPINE PAVILION
DESIGNED BY:	MSJ	LOCATION:
DATE/TIME:	07.29.24	TOKYO INTERNATIONAL EXHIBITION CENTER TOKYO, JAPAN
	SHEET CONTENT:	SHEET NO.:
	06 PEDESTAL A	25

06 PEDESTAL B DETAILS

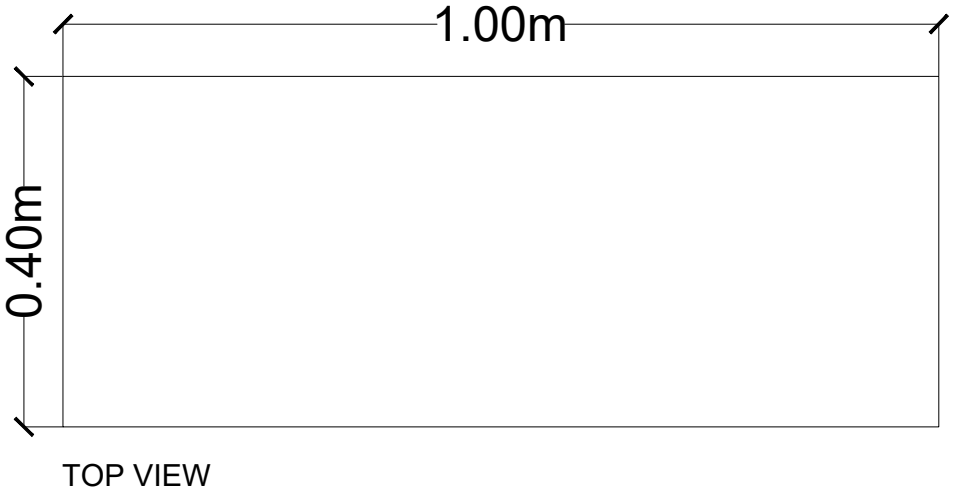

TOP VIEW

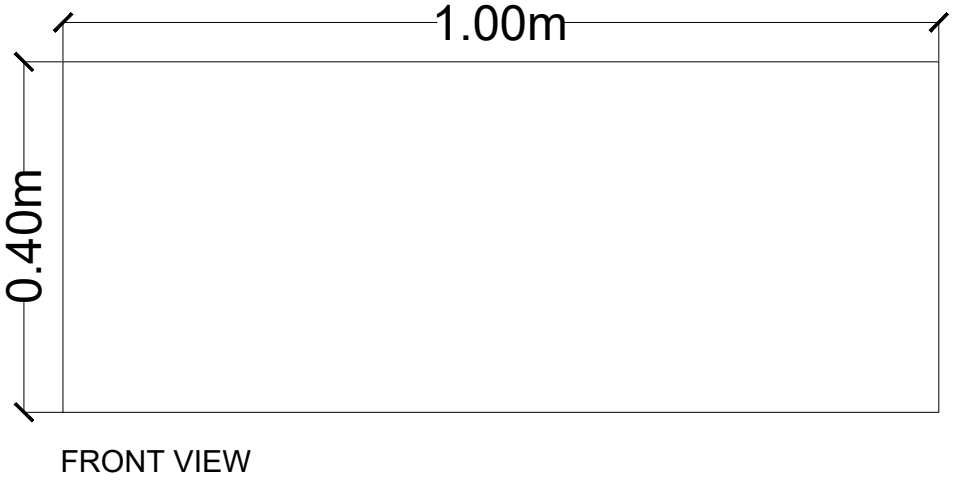

FRONT VIEW

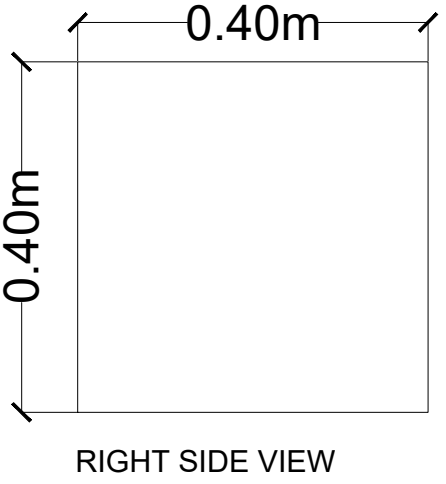

RIGHT SIDE VIEW

MATERIAL: 3/4 INCH PLYWOOD
WITH CEMENT PAINT FINISH

	<small>PROJECT:</small> TIGS 2024
	<small>TITLE:</small> PHILIPPINE PAVILION
	<small>LOCATION:</small> TOKYO INTERNATIONAL EXHIBITION CENTER TOKYO, JAPAN
<small>DESIGNED BY:</small> MSJ	<small>DATE/TIME:</small> 07.29.24
<small>SHEET CONTENT:</small> 06 PEDESTAL B	<small>SHEET NO.:</small> 26

06 PEDESTAL C DETAILS

WITH CONCEALED CABINET
SAME FINISH WITH
CEMENT WALL FINISH

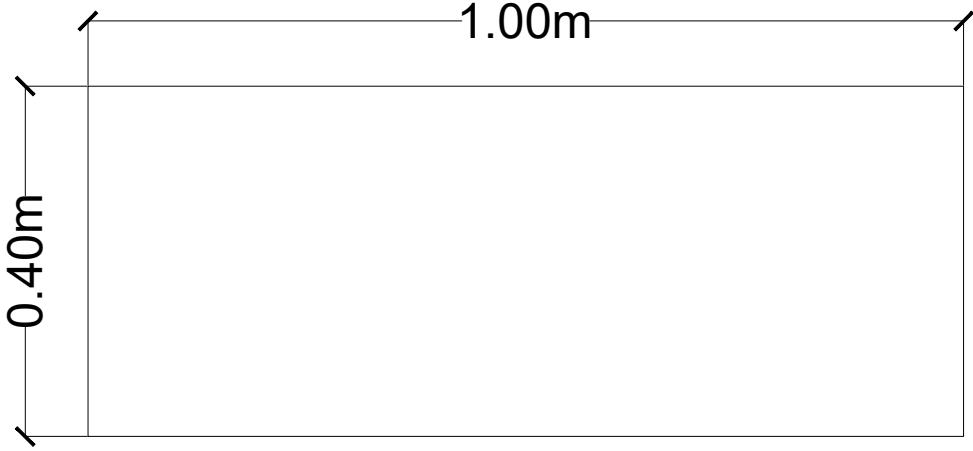

TOP VIEW

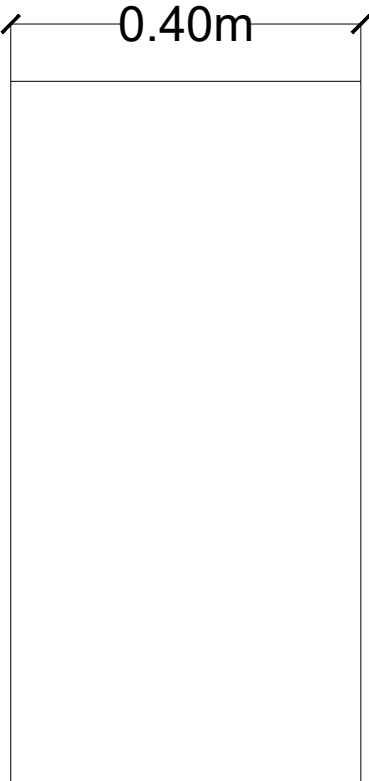

LEFT SIDE VIEW

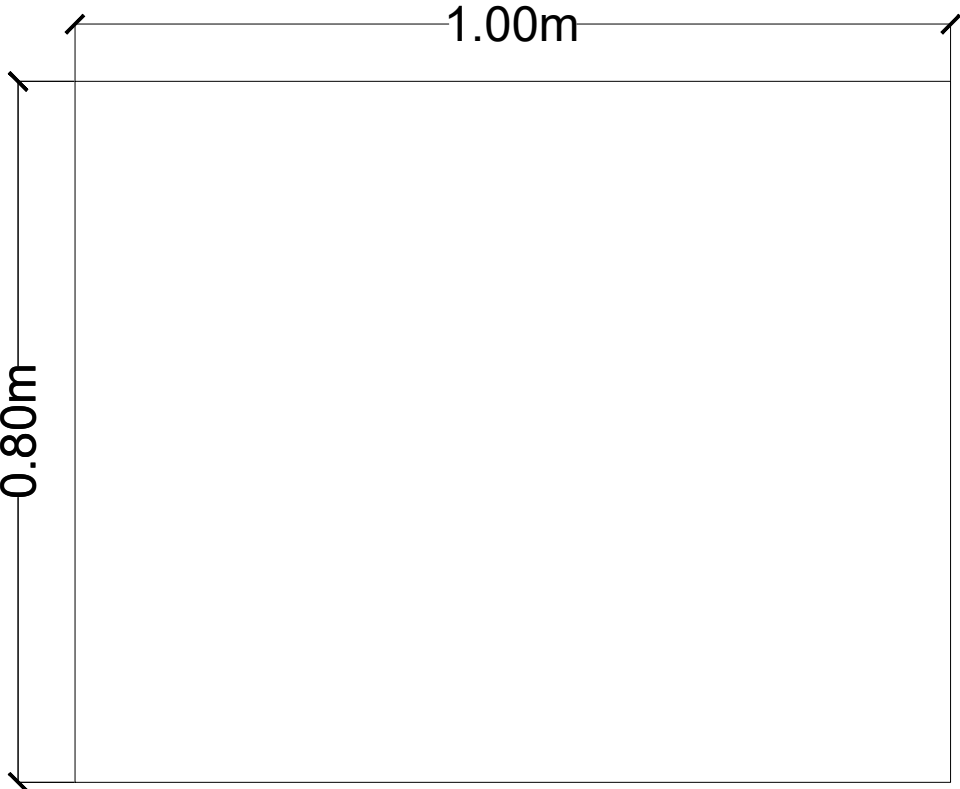

FRONT VIEW

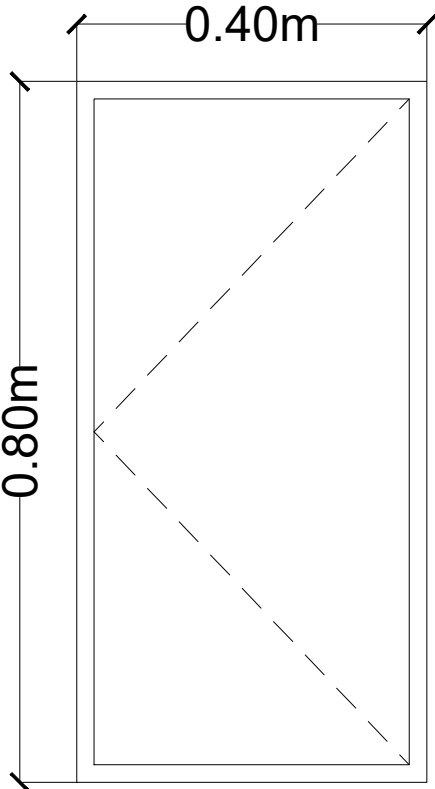

RIGHT SIDE VIEW

MATERIAL: 3/4 INCH PLYWOOD
WITH CEMENT PAINT FINISH

	PROJECT: TIGS 2024	
	TITLE: PHILIPPINE PAVILION	
DESIGNED BY: MSJ	LOCATION: TOKYO INTERNATIONAL EXHIBITION CENTER TOKYO, JAPAN	
DATE/TIME: 07.29.24	SHEET CONTENT: 06 PEDESTAL C	SHEET NO: 27